

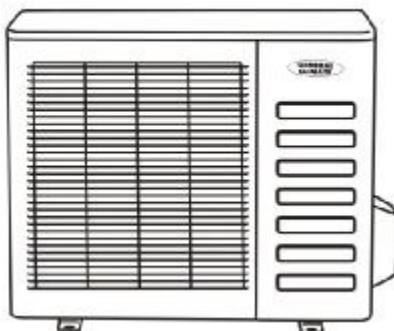

Service manual

Room air conditioner Split Wall-Mounted Type

GC/CU-S05CR
GC/CU-S07HR
GC/CU-S09HR
GC/CU-S12HR
GC/CU-S18HR

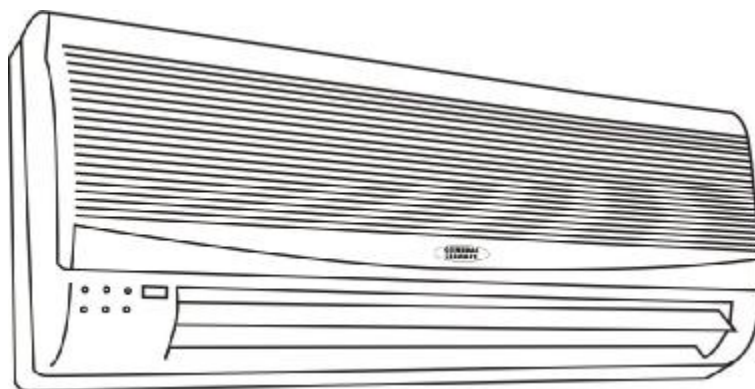

Большая библиотека технической документации

<https://splitsystema48.ru/instrukcii-po-ekspluatácii-kondicionerov.html>

каталоги, инструкции, сервисные мануалы, схемы.

Content

1. Precaution	1
1.1 Safety Precaution	1
1.2 Warning	1
2. Function	3
3. Dimension	5
3.1 Indoor unit	5
3.2 Outdoor unit	6
4. Specification	7
5. Refrigerant cycle diagram	9
6. Operation limits	10
6.1 Cooling operation	10
6.2 Heating operation	10
7. Schematic diagram and Wiring diagram	11
7.1 Schematic diagram	11
7.2 Wiring diagram	12
8. Installation details	15
8.1 Wrench torque sheet for installation	15
8.2 Connecting the cables	15
8.3 Pipe length and the elevation	15
8.4 Air purging of the piping and indoor unit	16
8.5 Pumping down (Re-installation)	17
8.6 Re-air purging (Re-installation)	18
8.7 Balance refrigerant of the 2-way, 3-way valves	19
8.8 Evacuation	20
8.9 Gas charging	21
9. Capacity table	22
9.1 GC/GU-S05CR	22
9.2 GC/GU-S07HR	22
9.3 GC/GU-S09HR	23
9.4 GC/GU-S12HR	23
9.5 GC/GU-S18HR	24
10. Electronic function	25
10.1 Electronic control working environment	25
10.2 Proper symbols and their meaning	25
10.3 Function	25
10.4 Protection	26
10.5 Fan-only mode	26
10.6 Cooling mode	26
10.7 Dehumidifying mode	27
10.8 Heating mode	28
10.9 Defrosting mode(available for heating mode)	29

10.10	Auto mode	30
10.11	Force cooling function	30
10.12	Sleep mode	31
10.13	Auto restart function	31
10.14	Anion (optional)	31
11.	Model and Parameters	33
12.	Troubleshooting	34
12.1	Display board	34
12.2	Troubleshooting	34
12.3	Diagnostic chart	35
12.4	Resetting phenomenon often occurs during operation.	36
12.5	Operation lamp flashes and Timer lamp off.	36
12.6	Operation lamp flashes and Timer lamp on.	36
12.7	Operation lamp off and Timer lamp flashes	37
12.8	Operation lamp on and Timer lamp flashes	37
12.9	Operation lamp flashes, Timer lamp flashes .	37
13.	Characteristic of temperature sensor	38

1. Precaution

1.1 Safety Precaution

- n To prevent injury to the user or other people and property damage, the following instructions must be followed.
- n Incorrect operation due to ignoring instruction will cause harm or damage.
- n Before service unit, be sure to read this service manual at first.

1.2 Warning

Ø Installation

- n Do not use a defective or underrated circuit breaker. Use this appliance on a dedicated circuit.
There is risk of fire or electric shock.
- n For electrical work, contact the dealer, seller, a qualified electrician, or an Authorized service center.
Do not disassemble or repair the product, there is risk of fire or electric shock.
- n Always ground the product.
There is risk of fire or electric shock.
- n Install the panel and the cover of control box securely.
There is risk of fire of electric shock.
- n Always install a dedicated circuit and breaker.
Improper wiring or installation may cause fore or electric shock.
- n Use the correctly rated breaker of fuse.
There is risk of fire or electric shock.
- n Do not modify or extend the power cable.
There is risk of fire or electric shock.
- n Do not install, remove, or reinstall the unit by yourself (customer).
There is risk of fire, electric shock, explosion, or injury.
- n Be caution when unpacking and installing the product.
Sharp edges could cause injury, be especially careful of the case edges and the fins on the condenser and evaporator.
- n For installation, always contact the dealer or an Authorized service center.
There is risk of fire, electric shock, explosion, or injury.
- n Do not install the product on a defective installation stand.
It may cause injury, accident, or damage to the product.
- n Be sure the installation area does not deteriorate with age.
If the base collapses, the air conditioner could fall with it, causing property damage, product failure, and personal injury.
- n Do not let the air conditioner run for a long time when the humidity is very high and a door or a windows is left open.
Moisture may condense and wet or damage furniture.
- n Take care to ensure that power cable could not be pulled out or damaged during operation.
There is risk of fire or electric shock.
- n Do not place anything on the power cable.
There is risk of fire or electric shock.
- n Do not plug or unplug the power supply plug during operation.
There is risk of fire or electric shock.
- n Do not touch (operation) the product with wet hands.
There is risk of fire or electric shock.
- n Do not place a heater or other appliance near the power cable.
There is risk of fire and electric shock.
- n Do not allow water to run into electric parts.
It may cause fire, failure of the product, or electric shock.
- n Do not store or use flammable gas or combustible near the product.
There is risk of fire or failure of product.
- n Do not use the product in a tightly closed space for a long time.
Oxygen deficiency could occur.
- n When flammable gas leaks, turn off the gas and open a window for ventilation before turn the product on.
Do not use the telephone or turn switches on or off. There is risk of explosion or fire.
- n If strange sounds, or small or smoke comes from product. Turn the breaker off or disconnect the power supply cable.
There is risk of electric shock or fire.
- n Stop operation and close the window in storm or hurricane. If possible, remove the product from the window before the hurricane arrives.

There is risk of property damage, failure of product, or electric shock.

- n Do not open the inlet grill of the product during operation. (Do not touch the electrostatic filter, if the unit is so equipped.)

There is risk of physical injury, electric shock, or product failure.

- n When the product is soaked (flooded or submerged), contact an Authorized service center.

There is risk of fire or electric shock.

- n Be caution that water could not enter the product.

There is risk of fire, electric shock, or product damage.

- n Ventilate the product from time to time when operating it together with a stove, etc.

There is risk of fire or electric shock.

- n Turn the main power off when cleaning or maintaining the product.

There is risk of electric shock.

- n When the product is not be used for a long time, disconnect the power supply plug or turn off the breaker.

There is risk of product damage or failure, or unintended operation.

- n Take care to ensure that nobody could step on or fall onto the outdoor unit.

This could result in personal injury and product damage.

Ø CAUTION

- n Always check for gas (refrigerant) leakage after installation or repair of product.

Low refrigerant levels may cause failure of product.

- n Install the drain hose to ensure that water is drained away properly.

A bad connection may cause water leakage.

- n Keep level even when installing the product.

To avoid vibration of water leakage.

- n Do not install the product where the noise or hot air from the outdoor unit could damage the neighborhoods.

It may cause a problem for your neighbors.

- n Use two or more people to lift and transport the product.

Avoid personal injury.

- n Do not install the product where it will be exposed to sea wind (salt spray) directly.

It may cause corrosion on the product. Corrosion, particularly on the condenser and evaporator fins, could cause product malfunction or inefficient operation.

Ø Operational

- n Do not expose the skin directly to cool air for long periods of time. (Do not sit in the draft).

This could harm to your health.

- n Do not use the product for special purposes, such as preserving foods, works of art, etc. It is a consumer air conditioner, not a precision refrigerant system.

There is risk of damage or loss of property.

- n Do not block the inlet or outlet of air flow.

It may cause product failure.

- n Use a soft cloth to clean. Do not use harsh detergents, solvents, etc.

There is risk of fire, electric shock, or damage to the plastic parts of the product.

- n Do not touch the metal parts of the product when removing the air filter. They are very sharp.

There is risk of personal injury.

- n Do not step on or put anything on the product. (outdoor units)

There is risk of personal injury and failure of product.

- n Always insert the filter securely. Clean the filter every two weeks or more often if necessary.

A dirty filter reduces the efficiency of the air conditioner and could cause product malfunction or damage.

- n Do not insert hands or other object through air inlet or outlet while the product is operated.

There are sharp and moving parts that could cause personal injury.

- n Do not drink the water drained from the product.

It is not sanitary could cause serious health issues.

- n Use a firm stool or ladder when cleaning or maintaining the product.

Be careful and avoid personal injury.

- n Replace the all batteries in the remote control with new ones of the same type. Do not mix old and new batteries or different types of batteries.

There is risk of fire or explosion.

- n Do not recharge or disassemble the batteries. Do not dispose of batteries in a fire.

They may burn or explode.

- n If the liquid from the batteries gets onto your skin or clothes, wash it well with clean water. Do not use the remote of the batteries have leaked.

The chemical in batteries could cause burns or other health hazards.

2. Function

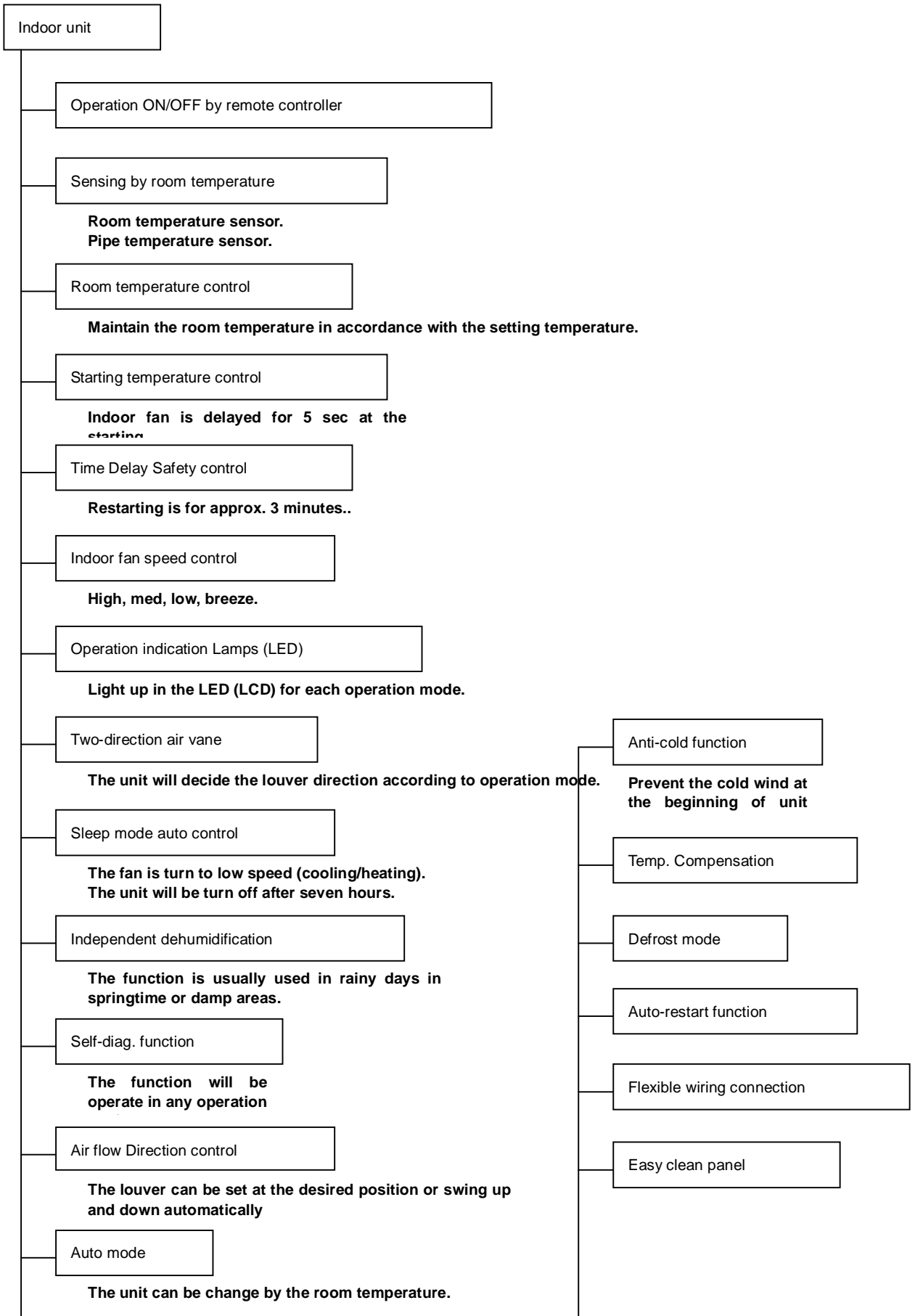

Outdoor unit

Power relay control

The unit has 3 mins delay between continuously ON/OFF operations.

Low ambient kit

The unit can operate in cooling mode at low ambient temperature conditions.

Low noise air flow system

Bird tail propeller fan makes the outdoor unit run more quietly.

Hydrophilic aluminum fin

The hydrophilic fin can improve the heating efficiency at operation mode.

4 way valve control

It is only operated in the heating operation mode except defrosting operation.

Discharge pipe temperature protect

Anti-rust cabinet

Made from electrolytic zinc steel sheet and anti-rust coated components.

Valve protection cover

It protects the valves and prevents water from dripping.

3. Dimension

3.1 Indoor unit

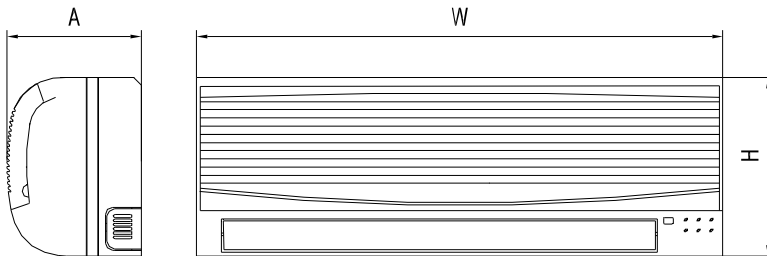

Dimension Mode	W	H	L
5K	750	250	188
7K	750	250	188
9K	750	250	188
12K	750	250	188
18K	906	286	235

3.2 Outdoor unit

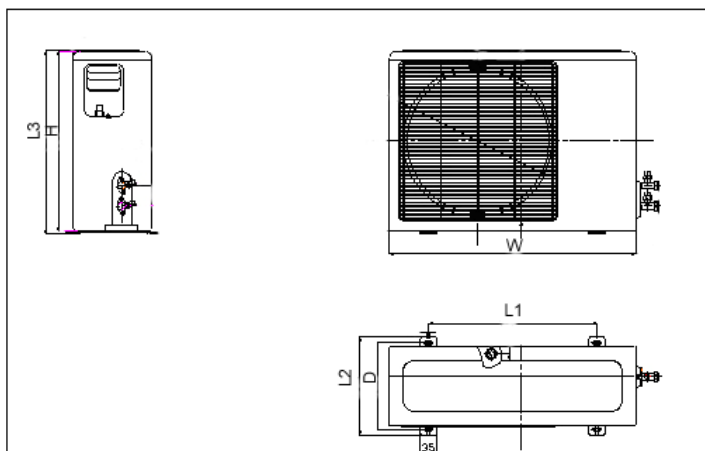

Dimension Mode	W	H	D	L1	L2	L3
5K	700	535	235	458	280	540
7K	700	535	235	458	280	540
9K	700	535	235	458	280	540
12K	780	540	250	530	315	590
18K	760	590	285	540	335	615

4. Specification

Model			GC/GU-S05CR	GC/GU-S07HR
Power supply		Ph-V-Hz	1, 220-240V~,50Hz	1, 220-240V~,50Hz
Cooling	Capacity	Btu/h	5000	7000
	Input	W	560	760
	Rated current	A	2,6	3,6
	EER	Btu/w.h	9	9,2
Heating	Capacity	Btu/h	-----	7600
	Input	W	-----	760
	Rated current	A	-----	3,4
	COP	W/W	-----	10
Max. current		A	3,8	5
Starting current		A	16	18
Compressor	Model		KH104VFHC	2P14C235ANA
	Type		Rotary	Rotary
	Brand		SHANGHAI SENLIN	GD Matsushita
	Capacity	Btu/h	5700	7500
	Input	W	590	725
	Rated current(RLA)	A	2,7	3,4
	Locked rotor Amp(LRA)	A	13	15
	Thermal protector		BF540-KB	MRA98854
	Capacitor	uF	15	25
Refrigerant oil	ml	MS-56 270	ATOMOS M60 270	
Indoor fan motor	Model		RPG13H	RPG13H
	Brand		WELLING	WELLING
	Input	W	36,5	36,5
	Capacitor	uF	1.2 μ F/450V	1.2 μ F/450V
	Speed(hi/mi/lo)	r/min	1020/ 960/ 900	1020/ 960/ 900
Indoor air flow (Hi/Mi/Lo)		m ³ /h	300/270/240	380/350/320
Indoor noise level (Hi/Mi/Lo)		dB(A)	32/30/28	32/30/28
Outdoor fan motor	Model		YDK24-6T	YDK24-6T
	Brand		WELLING	WELLING
	Input	W	70	70
	Capacitor	uF	3	3
Speed	r/min	850	850	
Outdoor air flow		m ³ /h	1400	1400
Outdoor noise level		dB(A)	49	49
Refrigerant type R22		g	480	620
Design pressure		MPa	2,6	2,6
Refrigerant piping	Liquid side/ Gas side	mm	ϕ 6.35/ ϕ 9.53	ϕ 6.35/ ϕ 9.53
	Max. refrigerant pipe length	m	10	10
	Max. difference in level	m	5	5
Operation temp		°C	17-30	17-30
Ambient temp		°C	18-45	-7 - 45
Application area		m ²	8-12	10-14

Note:

The noise data is base on hemi-anechoic chamber, during actual operation; these values are normally somewhat different as a result of ambient condition.

The above design and specifications are subject to change without prior notice for product improvement.

Model		GC/GU-S09HR	GC/GU-S12HR	GC/GU-S18HR
Power supply		Ph-V-Hz	1, 220-240V~,50Hz	1, 220-240V~,50Hz
Cooling	Capacity	Btu/h	9000	12000
	Input	W	960	1230
	Rated current	A	4,5	5,7
	EER	Btu/w.h	9,4	9,8
Heating	Capacity	Btu/h	10000	13000
	Input	W	980	1290
	Rated current	A	4,4	6
	COP	W/W	10,2	9,8
Max. current		A	7	9,1
Starting current		A	25	26
Compressor	Model		2P18S225ANK	PH225X2C-4FT
	Type		Rotary	Rotary
	Brand		GD Matsushita	GD Toshiba
	Capacity	Btu/h	9920	13610
	Input	W	970	1305
	Rated current(RLA)	A	4,5	6,1
	Locked rotor Amp(LRA)	A	24	26
	Thermal protector		External (MRA98745)	External
	Capacitor	uF	30	35
	Refrigerant oil	ml	SUNISO 350	430
Indoor fan motor	Model		RPG13H	RPG13H
	Brand		WELLING	WELLING
	Input	W	36,5	36,5
	Capacitor	uF	1.2 μ F/450V	1,2
	Speed(hi/mi/lo)	r/min	1100/1020/950	1350
Indoor air flow (Hi/Mi/Lo)		m ³ /h	450/420/390	550/500/460
Indoor noise level (Hi/Mi/Lo)		dB(A)	37/34/31	41/ 38 /34
Outdoor fan motor	Model		YDK24-6T	YDK24-6
	Brand		WELLING	WELLING
	Input	W	55	72
	Capacitor	uF	2.5 μ F/450V	2.5 μ F/450V
	Speed	r/min	800	850
Outdoor air flow		m ³ /h	1500	1800
Outdoor noise level		dB(A)	50	52
Refrigerant type R410A		g	650	820
Design pressure		MPa	2,6	2,6
Refrigerant piping	Liquid side/ Gas side	mm	ϕ 6.35/ ϕ 9.53	ϕ 6.35/ ϕ 12.7
	Max. refrigerant pipe length	m	10	15
	Max. difference in level	m	5	5
Operation temp		°C	17-30	17-30
Ambient temp		°C	-7 - 45	-7 - 45
Application area		m ²	14-21	18-26

Note:

The noise data is base on hemi-anechoic chamber, during actual operation; these values are normally somewhat different as a result of ambient condition.

The above design and specifications are subject to change without prior notice for product improvement.

5. Refrigerant cycle diagram

∅ Cooling only

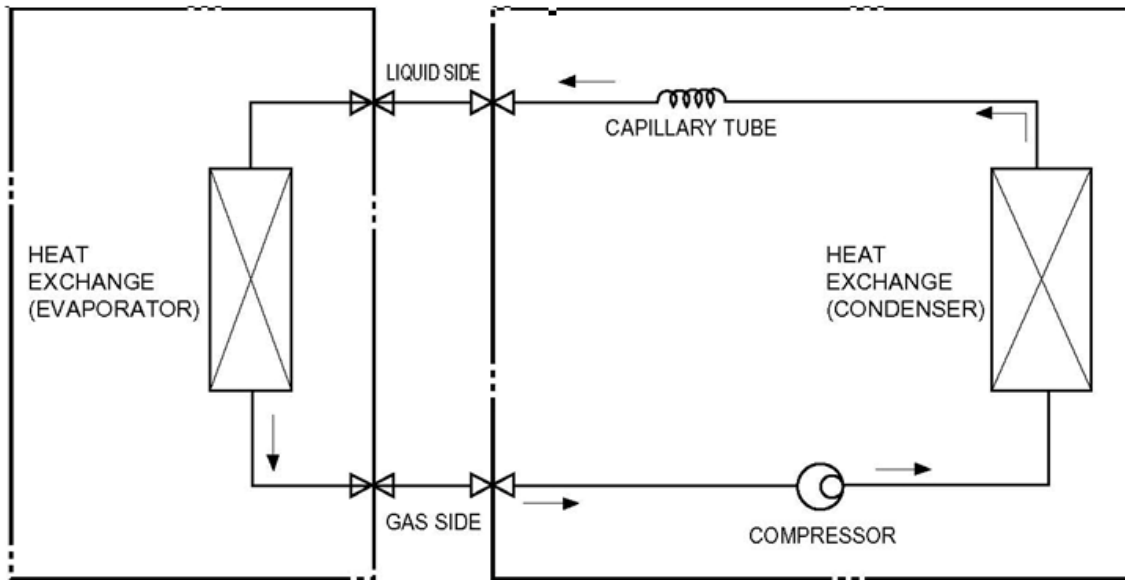

∅ Heat pump mode

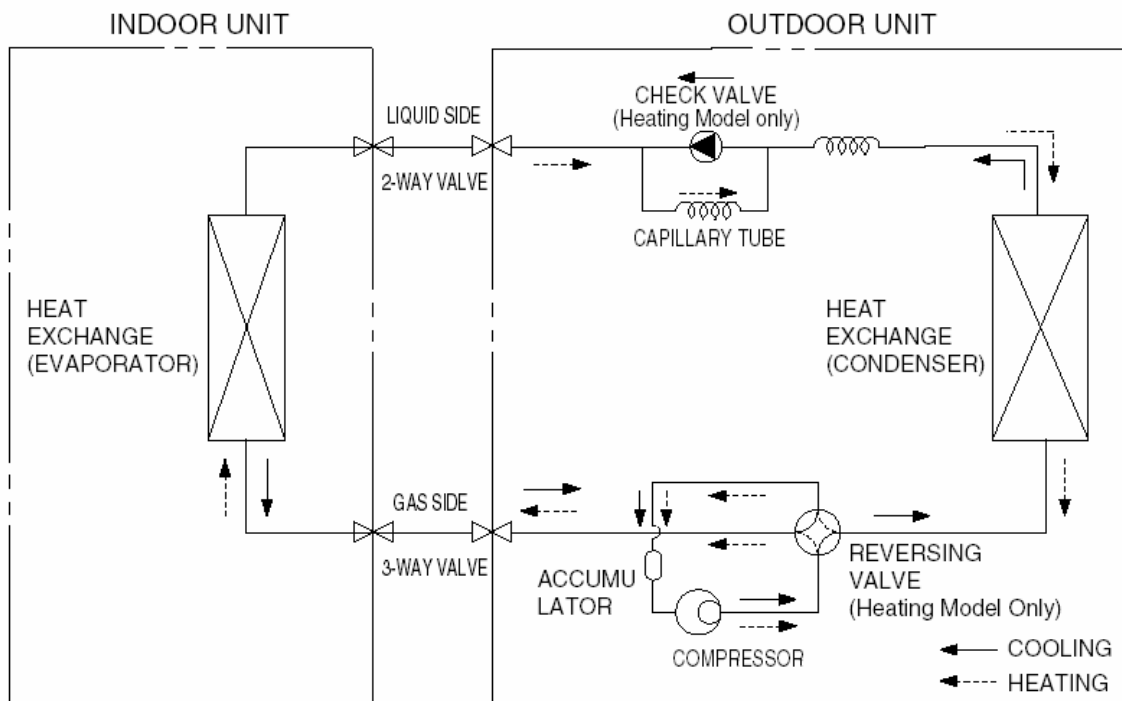

6. Operation limits

6.1 Cooling operation

Outdoor unit air temp. °C DB

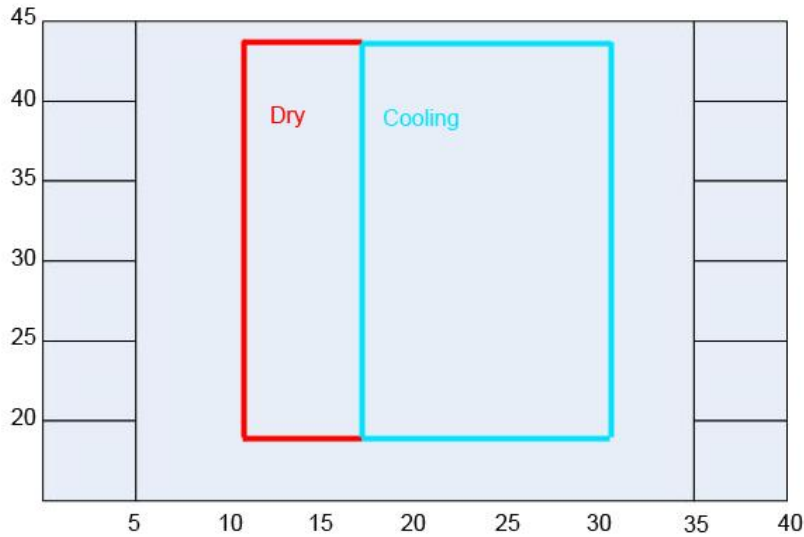

Indoor air temp. °C DB

Note: The chart is the result from the continuous operation under constant air temperature conditions. However, excludes the initial pull-down stage.

6.2 Heating operation

Indoor air temp. °C DB

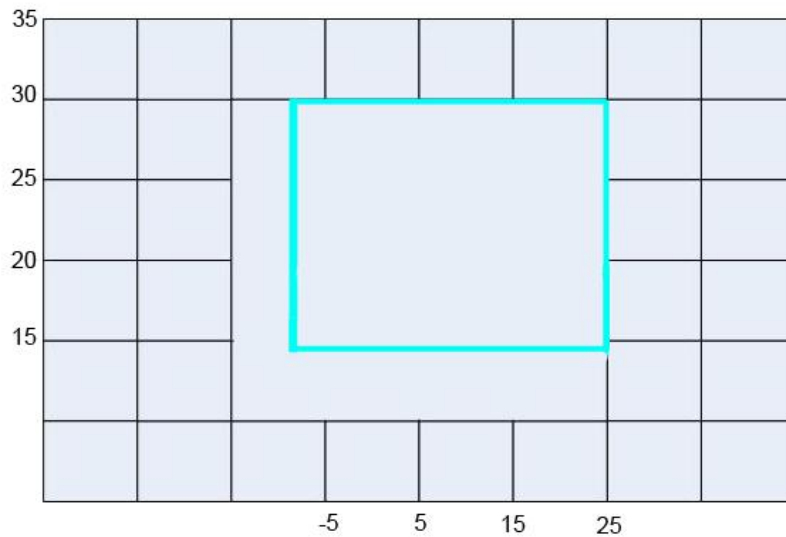

Outdoor unit air temp. °C DB

Note: The chart is the result from the continuous operation under constant air temperature conditions. However, excludes the initial pull-down stage.

7. Schematic diagram and Wiring diagram

7.1 Schematic diagram

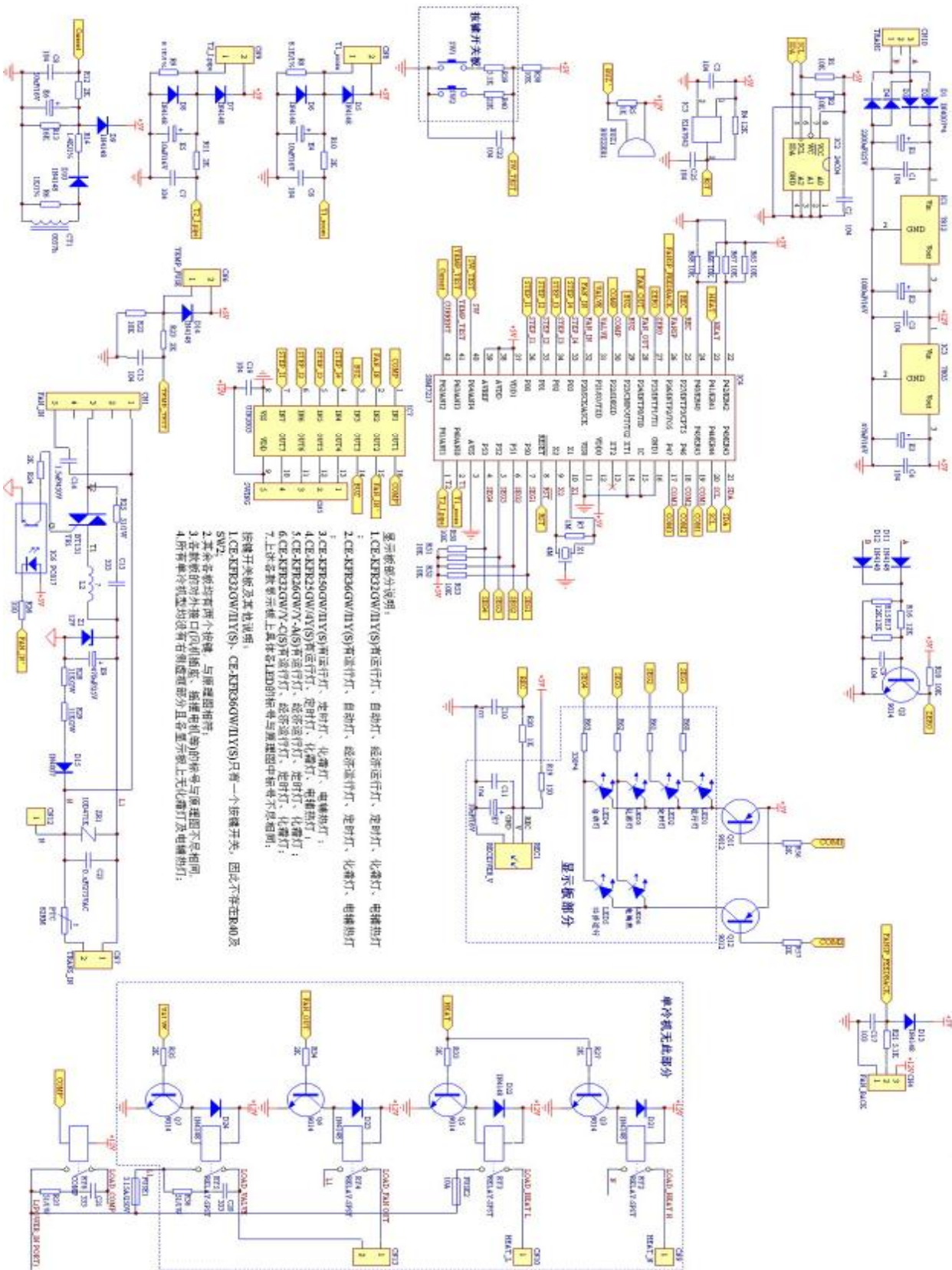

7.2 Wiring diagram

7.2.1 Cooling mode

GC/GU-S05CR

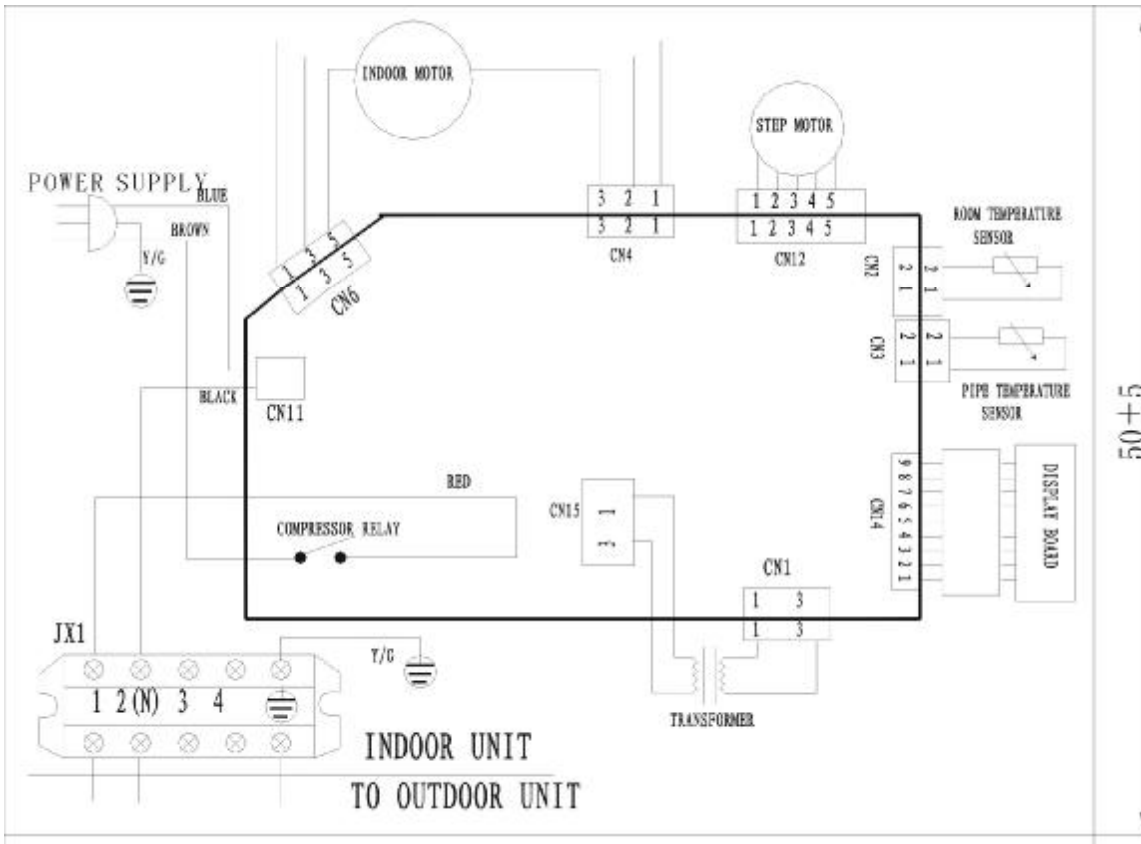

INDOOR UNIT

OUTDOOR UNIT

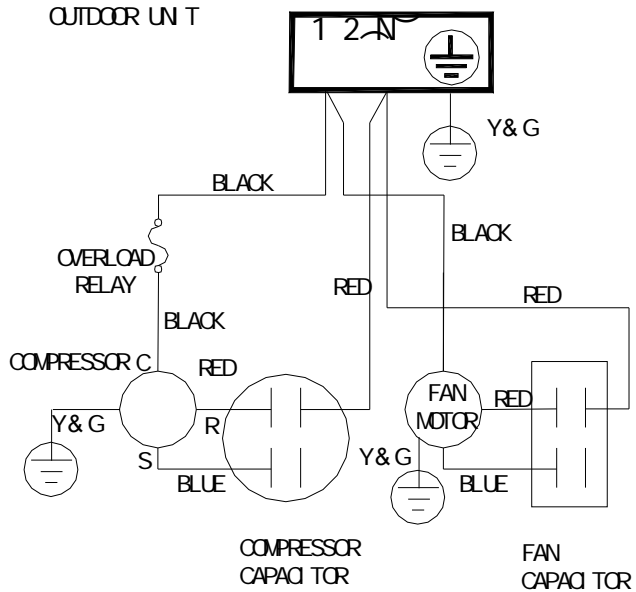

7.2.2 GC/GU-S07HR, GC/GU-S09HR, GC/GU-S12HR

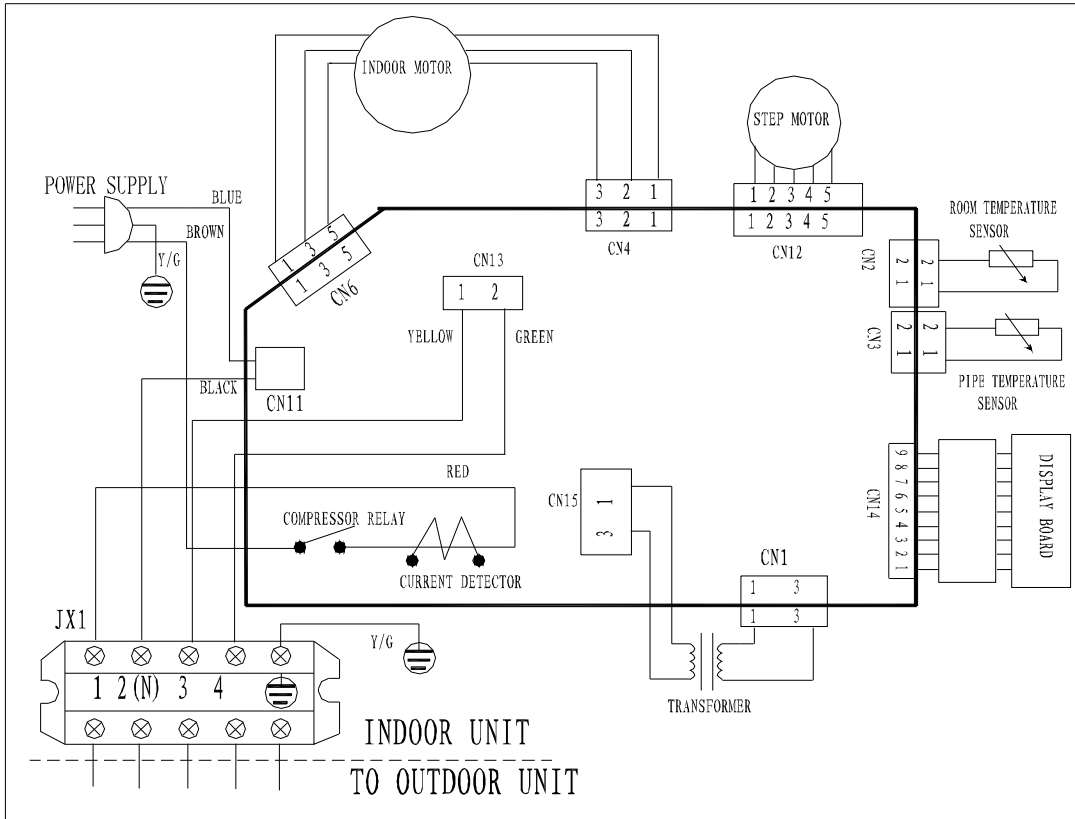

INDOOR UNIT

OUTDOOR UNIT

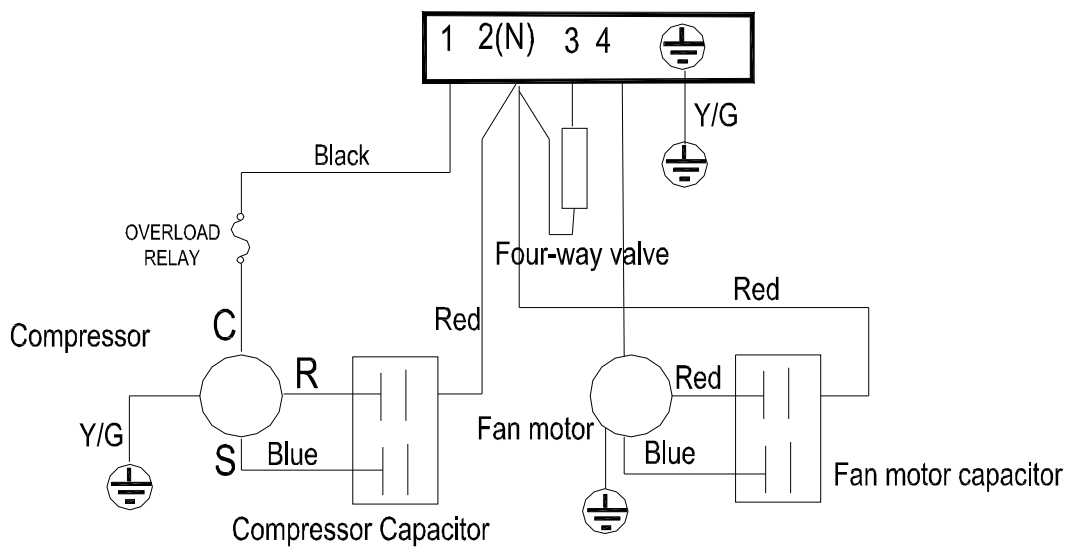

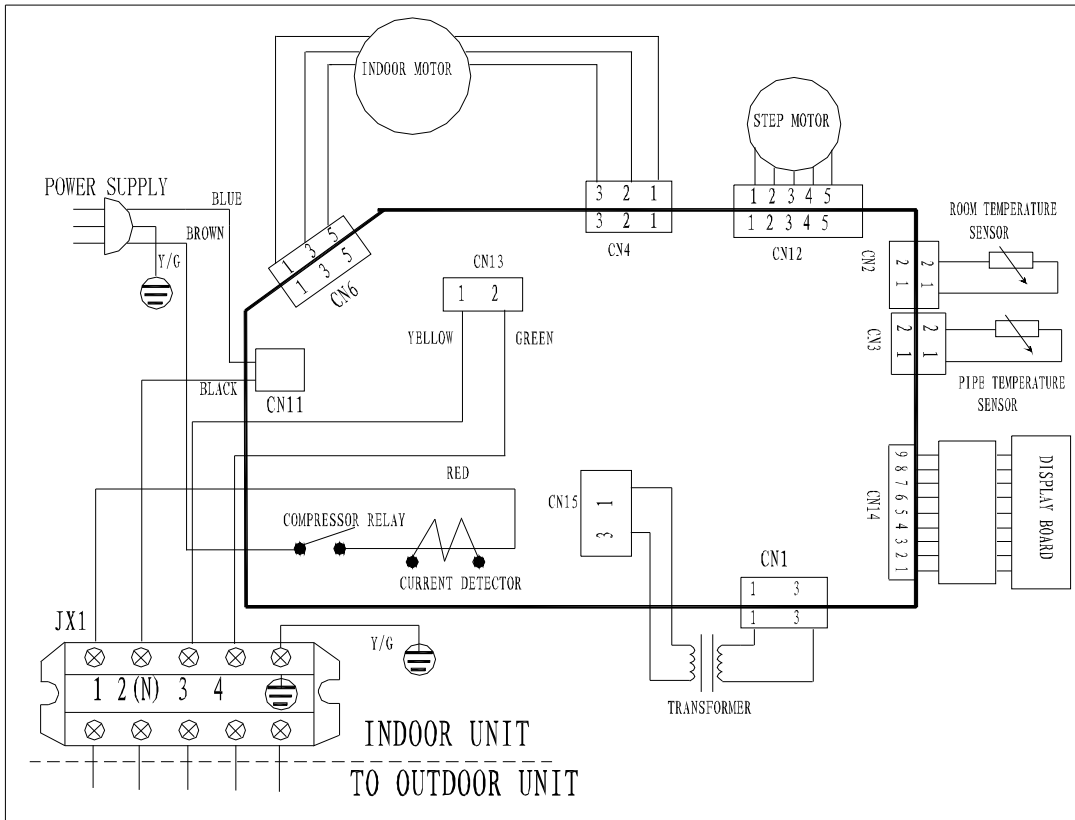

INDOOR UNIT

OUTDOOR UNIT

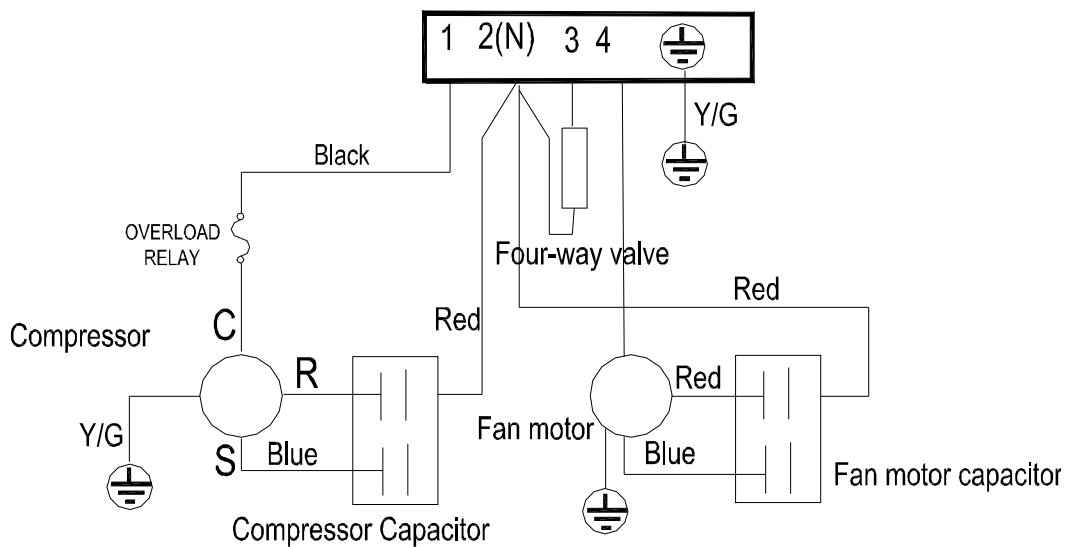

8. Installation details

8.1 Wrench torque sheet for installation

Outside diameter		Torque
mm	inch	Kg.m
φ6.35	1/4	1.8
φ9.52	3/8	4.2
φ12.7	1/2	5.5
φ15.88	5/8	6.6
φ19.05	3/4	6.6

8.2 Connecting the cables

The power cord of connect should be selected according to the following specifications sheet.

Grade				
Unit	7K	9K	12K	18K
mm ²	1,0	1,0	1,5	2,5

8.3 Pipe length and the elevation

Capacity	Pipe size		Standard length	Max.	Max.	Additional refrigerant
			(m)	Elevation	Elevation	
Btu/h	GAS	LIQUID		B (m)	A (m)	(g/m)
7k~12K	3/8" (φ9.52)	1/4" (φ6.35)	5	5	10	30
	1/2" (φ12.7)	1/4" (φ6.35)	5	5	10	30
18K	1/2" (φ12.7)	1/4" (φ6.35)	5	8	15	30

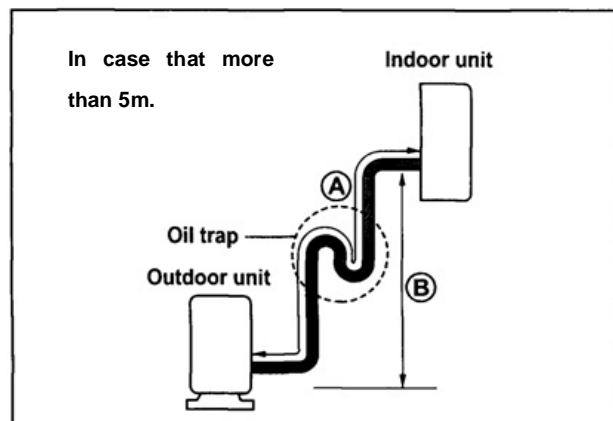
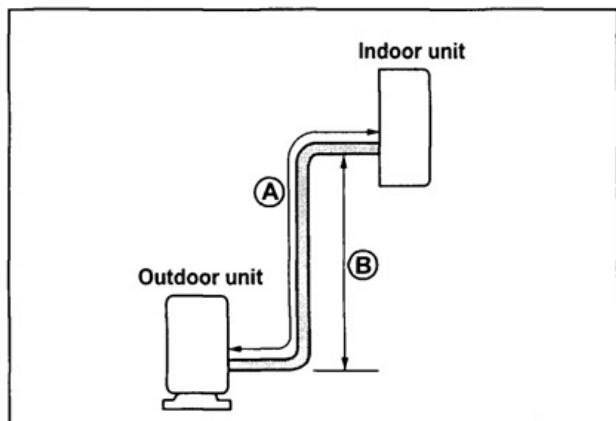

Caution:

Capacity is base on standard length and maximum allowance length is base of reliability.

Oil trap should be install per 5-7 meters.

8.4 Air purging of the piping and indoor unit

Required tools:

Hexagonal wrench; adjustable wrench; torque wrenches, wrench to hold the joints and gas leak detector.

Note:

The air in the indoor unit and in the piping must be purged. If air remains in the refrigeration piping, it will affect the compressor, reduce the cooling capacity, and could lead to a malfunction of unit.

Be sure, using a torque wrench to tighten the service port cap (after using the service port), so that it prevents the gas leakage from the refrigeration cycle.

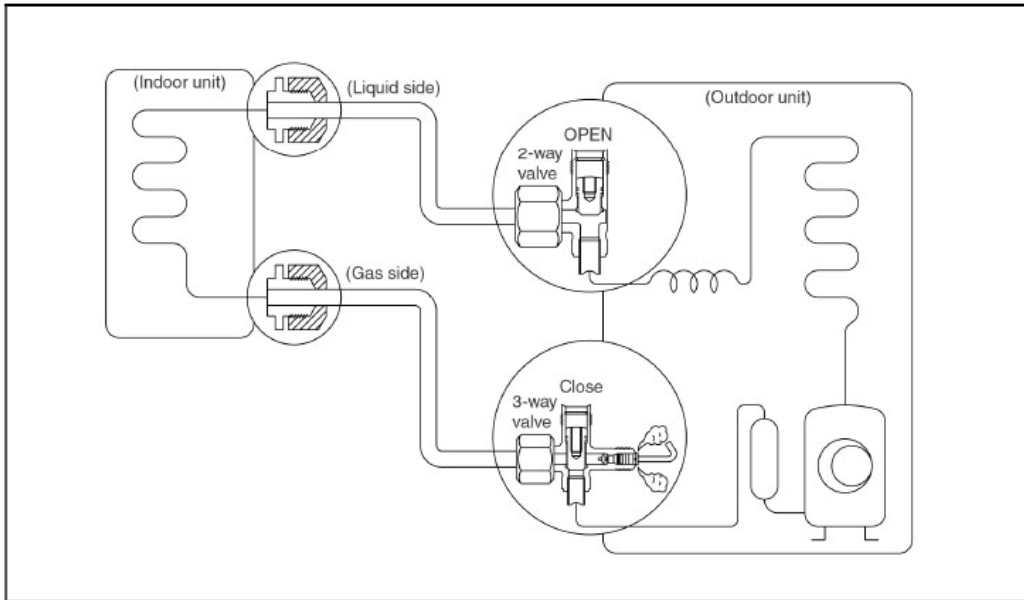

Procedure

1. Recheck the piping connections.
2. Open the valve stem of the 2-way valve counterclockwise approximately 90°, wait 10 seconds, and then set it to closed position.

§ Be sure to use a hexagonal wrench to operate the valve stem

3. Check for gas leakage.

§ Check the flare connection for gas leakage

4. Purge the air from the system.

§ Set the 2-way valve to the open position and remove the cap from the 3-way valve's service port.

§ Using the hexagonal wrench to press the valve core pin, discharge for three seconds and then wait for one minute.

5. Use torque wrench to tighten the service port cap to a torque of 1.8 kg.m. (18n.m)

6. Set the 3-way valve to the opened position.

7. Mounted the valve stem nuts to the 2-way and 3-way valves.

8. Check for gas leakage.

§ At this time, especially check for gas leakage from the 2-way and 3-way stem nuts, and from the service port.

Caution:

If gas leakage is discovered in step (3) above, take the following measures.

If the leaks stop when the piping connections are tightened further, continue working from step (4).

If the gas leaks do not stop when the connections are retightened, repair the location of the leak, discharge all of the gas through the service port, and then recharge with the specified amount of gas from a gas cylinder.

8.5 Pumping down (Re-installation)

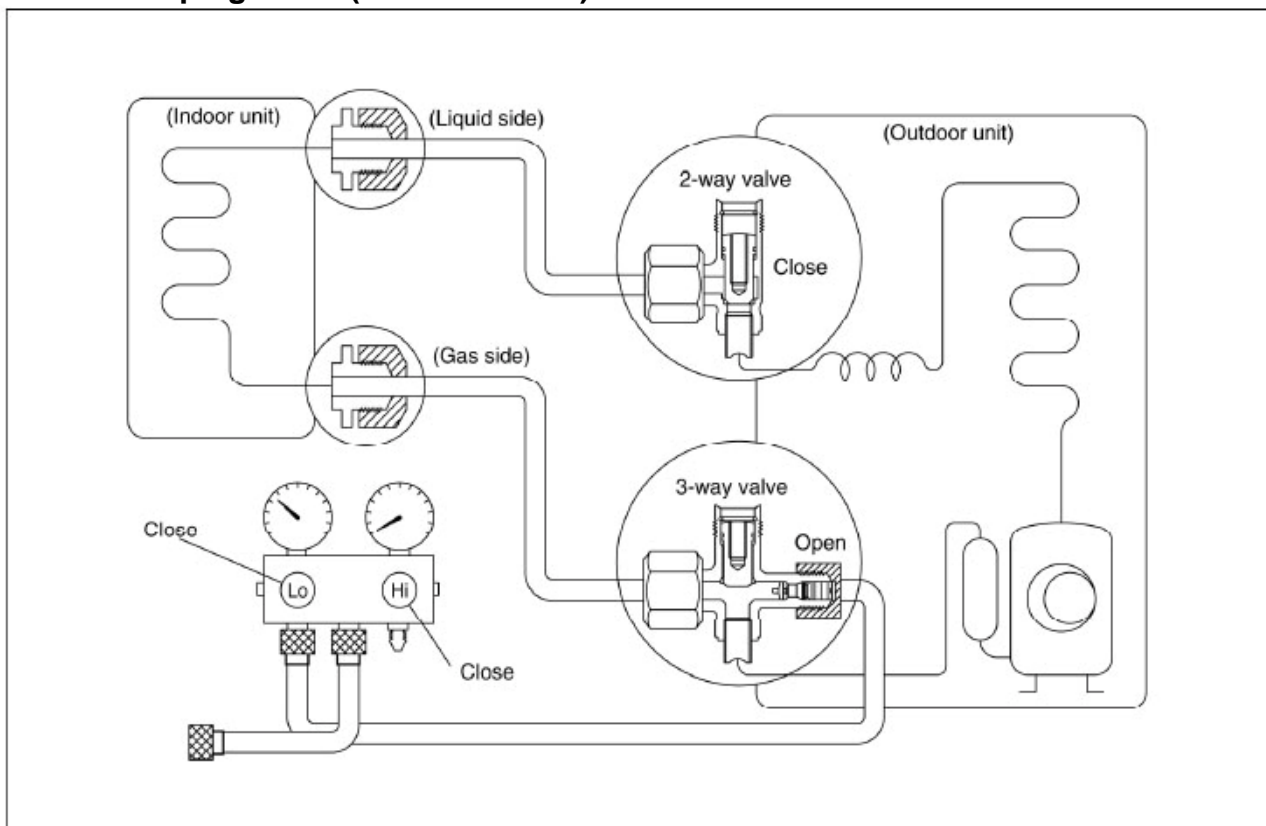

Procedure

1. Confirm that both the 2-way and 3-way valves are set to the opened position.
 - § Remove the valve stem caps and confirm that the valve stems are in the opened position.
 - § Be sure to use a hexagonal wrench to operate the valve stems.
2. Operate the unit for 10 to 15 minutes.
3. Stop operation and wait for 3 minutes, then connect the charge set to the service port of the 3-way valve.
 - § Connect the charge hose with the push pin to the gas service port.
4. Air purging of the charge hose.
 - § Open the low-pressure valve on the charge set slightly to purge air from the charge hose.
5. Set the 2-way valve to the close position.
6. Operate the air conditioner at the cooling cycle and stop it when the gauge indicates 0.1MPa.
7. Immediately set the 3-way valve to the closed position.
 - § Do this quickly so that the gauge ends up indicating 0.3 to 0.5Mpa.
8. Disconnect the charge set, and amount the 2-way and 3-way valve's stem nuts and service port caps.
 - § Use a torque wrench to tighten the service port cap to a torque of 1.8 kg.m.
 - § Be sure to check for gas leakage.

8.6 Re-air purging (Re-installation)

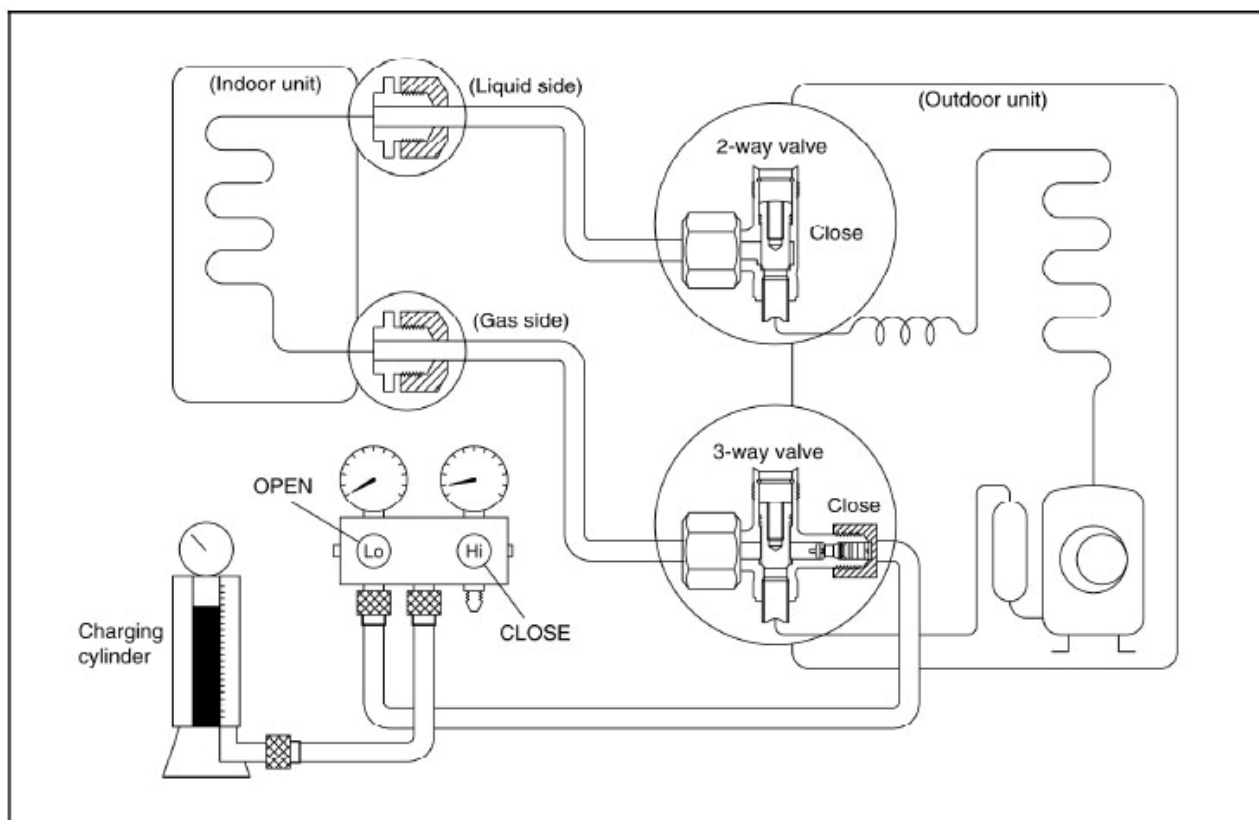

Procedure:

1. Confirm that both the 2-way and 3-way valves are set to the closed position.
2. Connect the charge set and a charging cylinder to the service port of the 3-way valve.
§ Leave the valve on the charging cylinder closed.
3. Air purging.
§ Open the valves on the charging cylinder and the charge set. Purge the air by loosening the flare nut on the 2-way valve approximately 45° for 3 seconds then closing it for 1 minutes; repeat 3 times.
§ After purging the air, use a torque wrench to tighten the flare nut to on the 2-way valve.
4. Check the gas leakage.
§ Check the flare connections for gas leakage.
5. Discharge the refrigerant.
§ Close the valve on the charging cylinder and discharge the refrigerant until the gauge indicate 0.3 to 0.5 Mpa.
6. Disconnect the charge set and the charging cylinder, and set the 2-way and 3-way valves to the open position.
§ Be sure to use a hexagonal wrench to operate the valve stems.
7. Mount the valve stems nuts and the service port cap.
§ Be sure to use a torque wrench to tighten the service port cap to a torque 18N.m.
§ Be sure to check the gas leakage.

8.7 Balance refrigerant of the 2-way, 3-way valves

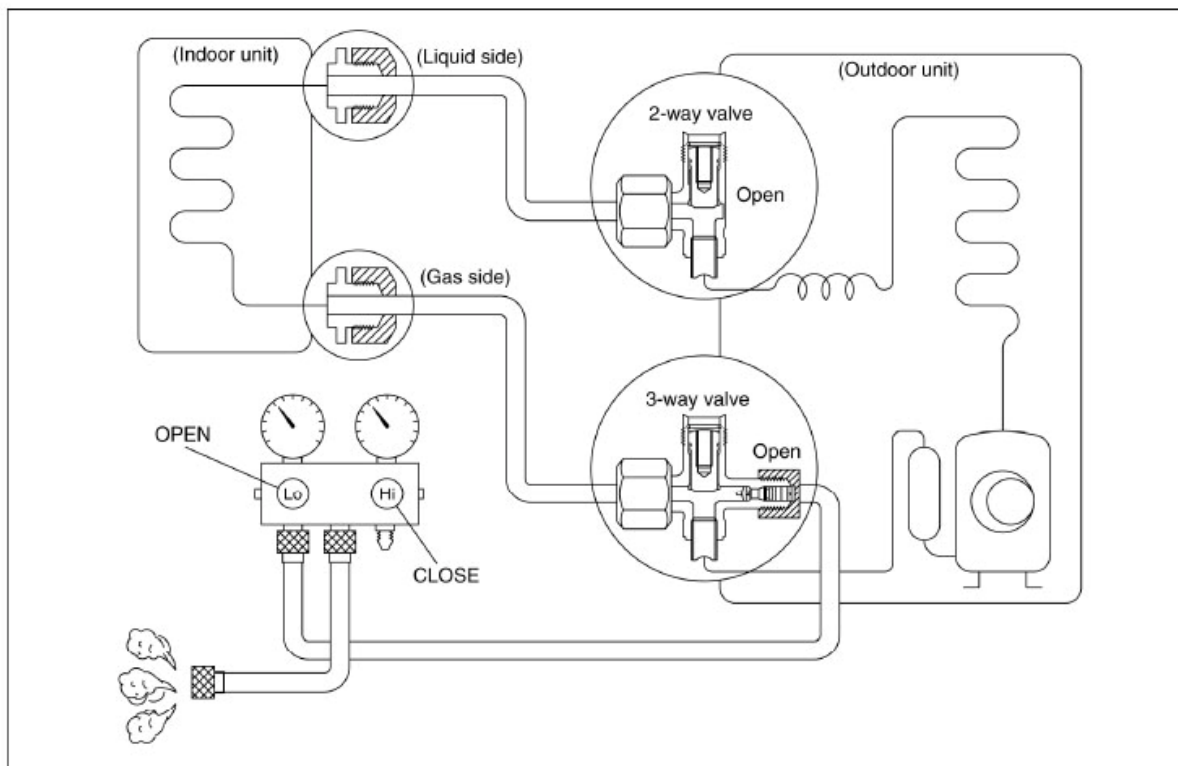

Procedure:

1. Confirm that both the 2-way and 3-way valves are set to the open position.
2. Connect the charge set to the 3-way valve's service port.
 - § Leave the valve on the charge set closed.
 - § Connect the charge hose with the push pin to the service port.
3. Open the valves (Low side) on the charge set and discharge the refrigerant until the gauge indicates 0.05 to 0.1 Mpa.
 - § If there is no air in the refrigeration cycle [the pressure when the air conditioner is not running is higher than 0.1Mpa, discharge the refrigerant until the gauge indicates 0.05 to 0.1 Mpa. If this is the case, it will not be necessary to apply a evacuation.
 - § Discharge the refrigeration gradually; if it is discharged too suddenly, the refrigeration oil will be discharged.

8.8 Evacuation

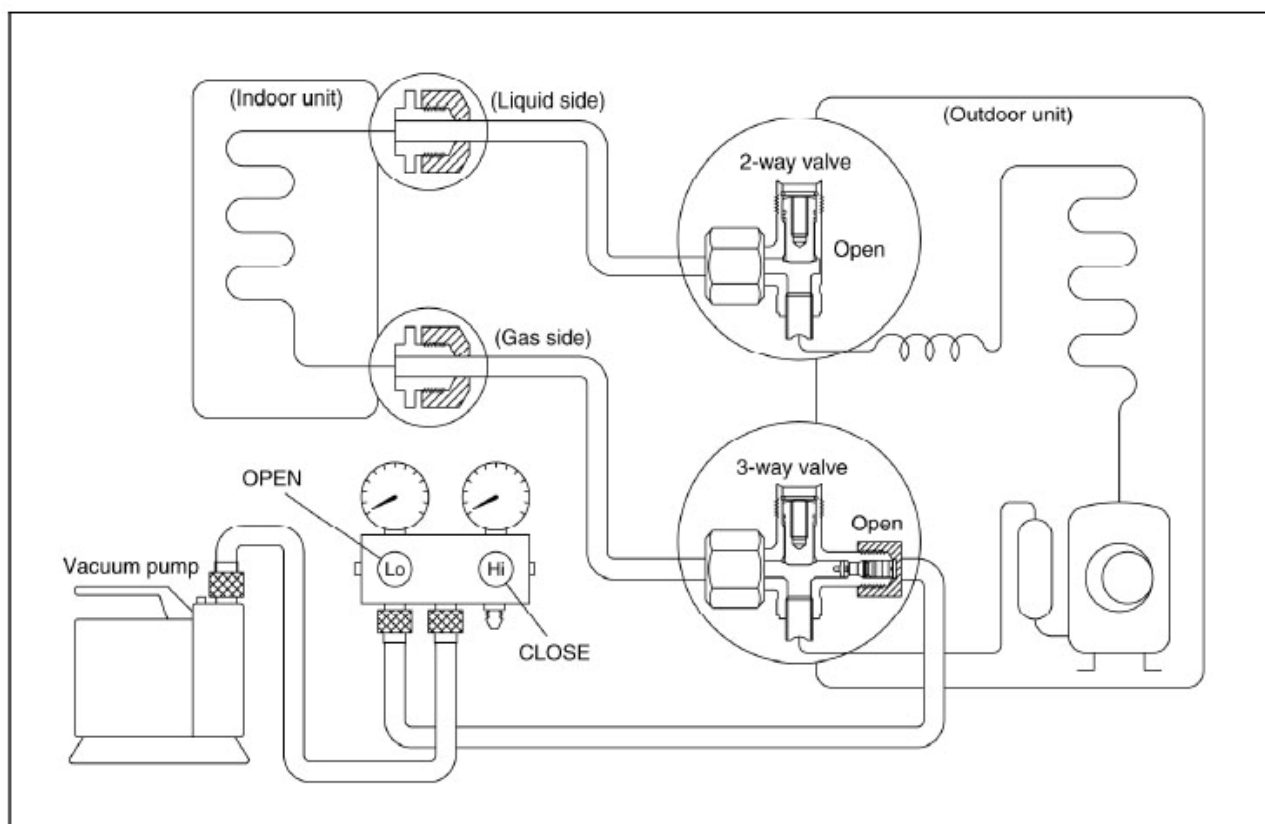

Procedure:

1. Connect the vacuum pump to the charge set's centre hose.
2. Evacuation for approximately one hour.
§ **Confirm that the gauge needle has moved toward -0.1 Mpa (-76 cmHg) [vacuum of 4 mmHg or less].**
3. Close the valve (Low side) on the charge set, turn off the vacuum pump, and confirm that the gauge needle does not move (approximately 5 minutes after turning off the vacuum pump).
4. Disconnect the charge hose from the vacuum pump.
§ **Vacuum pump oil, if the vacuum pump oil becomes dirty or depleted, replenish as needle.**

8.9 Gas charging

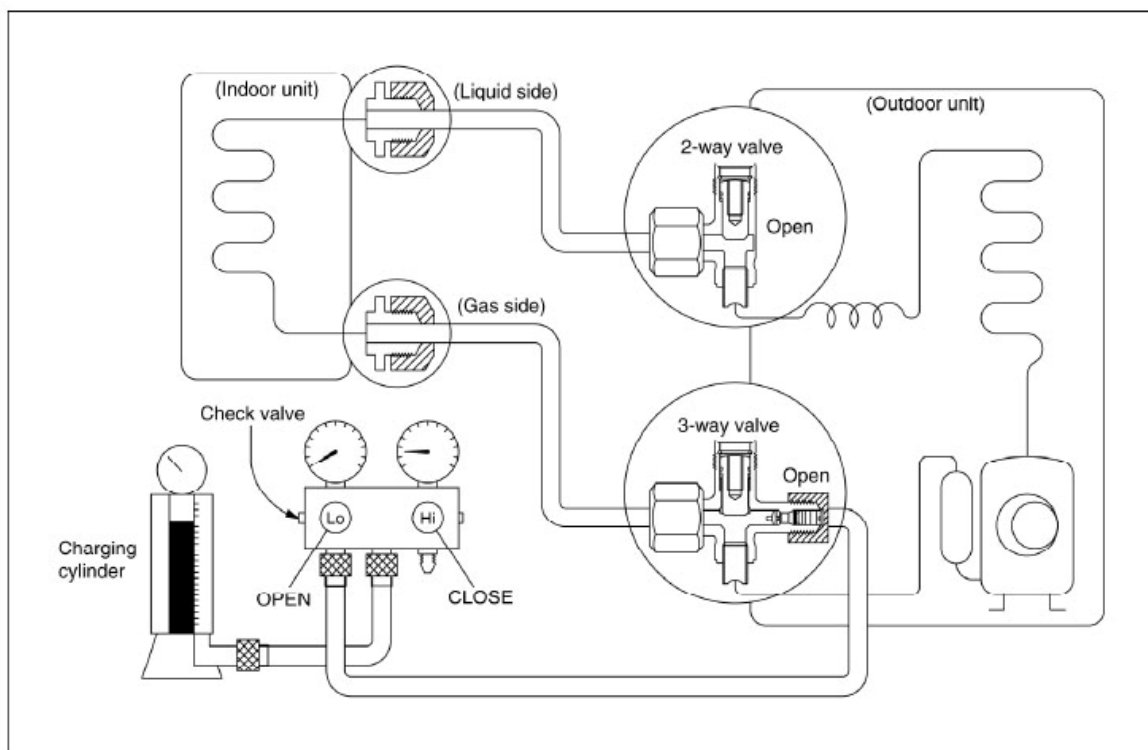

Procedure:

1. Connect the charge hose to the charging cylinder.
§ **Connect the charge hose which you disconnected from the vacuum pump to the valve at the bottom of the cylinder.**
2. Purge the air from the charge hose.
§ **Open the valve at the bottom of the cylinder and press the check valve on the charge set to purge the air (be careful of the liquid refrigerant).**
3. Open the valves (Low side) on the charge set and charge the system with liquid refrigerant.
§ **If the system cannot be charge with the specified amount of refrigerant, it can be charged with a little at a time (approximately 150g each time) while operating the air conditioner in the cooling cycle; however, one time is not sufficient, wait approximately 1 minute and then repeat the procedure.(pumping down-pin).**
4. Immediately disconnect the charge hose from the 3-way valve's service port.
§ **Stopping partway will allow the refrigerant to be discharged.**
§ **If the system has been charged with liquid refrigerant while operating the air conditioner, turn off the air conditioner before disconnecting the hose.**
5. Mounted the valve stem caps and the service port
§ **Use torque wrench to tighten the service port cap to a torque of 18N.m.**
§ **Be sure to check for gas leakage.**

9. Capacity table

9.1 GC/GU-S05CR

SUMMER	Cooling mode	OUTDOOR TEMPERATURE DRY					
Indoor Conditions		25°C	30°C	35°C	40°C	45°C	50°C
21°C D 15°C W	Total capacity kW	1.41	1.33	1.23	1.13	1.06	0.98
	Sensitive capacity kW	1.03	0.99	0.93	0.86	0.81	0.76
	Input kW.	0.48	0.51	0.53	0.57	0.63	0.65
24°C D 17°C W	Total capacity kW	1.53	1.46	1.37	1.29	1.20	1.11
	Sensitive capacity kW	1.12	1.09	1.04	0.99	0.93	0.86
	Input kW.	0.49	0.52	0.54	0.59	0.65	0.67
27°C D 19°C W	Total capacity kW	1.63	1.56	1.47	1.39	1.30	1.19
	Sensitive capacity kW	1.24	1.20	1.15	1.09	1.02	0.94
	Input kW.	0.51	0.54	0.56	0.60	0.67	0.69
32°C D 23°C W	Total capacity kW	1.81	1.74	1.68	1.57	1.43	1.35
	Sensitive capacity kW	1.40	1.36	1.32	1.24	1.14	1.09
	Input kW.	0.53	0.56	0.58	0.63	0.70	0.72

9.2 GC/GU-S07HR

SUMMER	Cooling mode	OUTDOOR TEMPERATURE DRY					
Indoor Conditions		25°C	30°C	35°C	40°C	45°C	50°C
21°C D 15°C W	Total capacity kW	1.97	1.85	1.71	1.58	1.47	1.37
	Sensitive capacity kW	1.44	1.38	1.29	1.20	1.13	1.05
	Input kW.	0.65	0.69	0.71	0.77	0.86	0.89
24°C D 17°C W	Total capacity kW	2.13	2.04	1.90	1.80	1.68	1.55
	Sensitive capacity kW	1.57	1.52	1.45	1.38	1.29	1.20
	Input kW.	0.67	0.71	0.74	0.80	0.88	0.91
27°C D 19°C W	Total capacity kW	2.27	2.17	2.05	1.94	1.81	1.66
	Sensitive capacity kW	1.73	1.67	1.60	1.52	1.42	1.32
	Input kW.	0.69	0.73	0.76	0.82	0.91	0.94
32°C D 23°C W	Total capacity kW	2.53	2.43	2.35	2.18	2.00	1.88
	Sensitive capacity kW	1.95	1.89	1.84	1.72	1.60	1.52
	Input kW.	0.72	0.76	0.79	0.85	0.95	0.98

WINTER		OUTDOOR CONDITIONS					
Indoor Conditions		12°C D 11°C W	7°C D 6°C W	4°C D 3°C W	0°C D -1°C W	-4°C D -6°C W	-7°C D -8°C W
15°C	Capacity kW	2.62	2.30	2.10	1.85	1.59	1.40
	Input kW.	0.78	0.71	0.66	0.61	0.53	0.48
18°C	Capacity kW	2.57	2.26	2.05	1.78	1.51	1.31
	Input kW.	0.80	0.72	0.67	0.63	0.55	0.49
20°C	Capacity kW	2.55	2.22	2.03	1.74	1.43	1.19
	Input kW.	0.83	0.73	0.69	0.64	0.57	0.52
22°C	Capacity kW	2.52	2.20	2.00	1.71	1.41	1.16
	Input kW.	0.86	0.74	0.70	0.67	0.60	0.54

9.3 GC/GU-S09HR

SUMMER	Cooling mode	OUTDOOR TEMPERATURE DRY					
Indoor Conditions		25°C	30°C	35°C	40°C	45°C	50°C
21°C D 15°C W	Total capacity kW	2.50	2.35	2.17	2.00	1.87	1.73
	Sensitive capacity kW	1.82	1.75	1.64	1.52	1.43	1.34
	Input kW.	0.86	0.90	0.94	1.02	1.13	1.17
24°C D 17°C W	Total capacity kW	2.71	2.58	2.42	2.28	2.13	1.96
	Sensitive capacity kW	1.99	1.93	1.84	1.75	1.64	1.52
	Input kW.	0.88	0.93	0.97	1.05	1.16	1.20
27°C D 19°C W	Total capacity kW	2.88	2.75	2.60	2.46	2.29	2.11
	Sensitive capacity kW	2.19	2.12	2.03	1.93	1.80	1.67
	Input kW.	0.91	0.96	1.00	1.08	1.20	1.24
32°C D 23°C W	Total capacity kW	3.21	3.08	2.98	2.77	2.53	2.38
	Sensitive capacity kW	2.47	2.40	2.34	2.19	2.02	1.93
	Input kW.	0.95	1.00	1.04	1.12	1.25	1.29
WINTER		OUTDOOR CONDITIONS					
Indoor Conditions		12°C D 11°C W	7°C D 6°C W	4°C D 3°C W	0°C D -1°C W	-4°C D -6°C W	-7°C D -8°C W
15°C	Capacity kW	3,46	3,03	2,78	2,44	2,10	1,84
	Input kW.	1,05	0,96	0,89	0,82	0,72	0,65
18°C	Capacity kW	3,39	2,98	2,71	2,35	1,99	1,73
	Input kW.	1,08	0,97	0,90	0,84	0,74	0,66
20°C	Capacity kW	3,36	2,93	2,68	2,29	1,89	1,56
	Input kW.	1,11	0,98	0,93	0,86	0,76	0,70
22°C	Capacity kW	3,33	2,90	2,64	2,26	1,85	1,54
	Input kW.	1,15	0,99	0,95	0,90	0,81	0,72

9.4 GC/GU-S12HR

SUMMER	Cooling mode	OUTDOOR TEMPERATURE DRY					
Indoor Conditions		25°C	30°C	35°C	40°C	45°C	50°C
21°C D 15°C W	Total capacity kW	3.36	3.16	2.93	2.69	2.52	2.33
	Sensitive capacity kW	2.46	2.36	2.21	2.05	1.92	1.80
	Input kW.	1.05	1.11	1.16	1.25	1.39	1.43
24°C D 17°C W	Total capacity kW	3.64	3.48	3.25	3.07	2.86	2.64
	Sensitive capacity kW	2.68	2.59	2.47	2.35	2.21	2.05
	Input kW.	1.09	1.15	1.19	1.29	1.43	1.48
27°C D 19°C W	Total capacity kW	3.88	3.71	3.50	3.31	3.08	2.84
	Sensitive capacity kW	2.95	2.85	2.73	2.60	2.43	2.25
	Input kW.	1.12	1.18	1.23	1.33	1.48	1.53
32°C D 23°C W	Total capacity kW	4.32	4.14	4.01	3.73	3.41	3.21
	Sensitive capacity kW	3.33	3.23	3.15	2.94	2.73	2.60
	Input kW.	1.16	1.23	1.28	1.38	1.54	1.59
WINTER		OUTDOOR CONDITIONS					
Indoor Conditions		12°C D 11°C W	7°C D 6°C W	4°C D 3°C W	0°C D -1°C W	-4°C D -6°C W	-7°C D -8°C W
15°C	Capacity kW	4.50	3.94	3.61	3.17	2.73	2.40
	Input kW.	1.38	1.26	1.17	1.08	0.94	0.86
18°C	Capacity kW	4.41	3.87	3.52	3.06	2.59	2.25
	Input kW.	1.42	1.28	1.19	1.11	0.97	0.87
20°C	Capacity kW	4.37	3.81	3.48	2.98	2.45	2.03
	Input kW.	1.46	1.29	1.23	1.14	1.00	0.92
22°C	Capacity kW	4.33	3.77	3.43	2.94	2.41	2.00
	Input kW.	1.51	1.30	1.24	1.18	1.06	0.95

9.5 GC/GU-S18HR

SUMMER		OUTDOOR TEMPERATURE DRY					
Indoor Conditions	Cooling mode	25°C	30°C	35°C	40°C	45°C	50°C
21°C D 15°C W	Total capacity kW	5.08	4.77	4.41	4.06	3.80	3.52
	Sensitive capacity kW	3.71	3.56	3.33	3.09	2.90	2.71
	Input kW.	1.56	1.64	1.71	1.85	2.05	2.12
24°C D 17°C W	Total capacity kW	5.49	5.25	4.91	4.64	4.32	3.98
	Sensitive capacity kW	4.04	3.91	3.73	3.55	3.33	3.09
	Input kW.	1.61	1.69	1.77	1.91	2.12	2.19
27°C D 19°C W	Total capacity kW	5.85	5.59	5.28	4.99	4.65	4.29
	Sensitive capacity kW	4.45	4.31	4.12	3.92	3.67	3.39
	Input kW.	1.66	1.75	1.82	1.97	2.18	2.26
32°C D 23°C W	Total capacity kW	6.52	6.25	6.05	5.62	5.14	4.84
	Sensitive capacity kW	5.02	4.88	4.75	4.44	4.11	3.92
	Input kW.	1.72	1.82	1.89	2.04	2.27	2.35
WINTER		OUTDOOR CONDITIONS					
Indoor Conditions		12°C D 11°C W	7°C D 6°C W	4°C D 3°C W	0°C D -1°C W	-4°C D -6°C W	-7°C D -8°C W
15°C	Capacity kW	6.57	5.76	5.28	4.64	3.99	3.51
	Input kW.	1.93	1.76	1.63	1.51	1.32	1.19
18°C	Capacity kW	6.45	5.66	5.15	4.47	3.79	3.28
	Input kW.	1.98	1.78	1.66	1.55	1.36	1.21
20°C	Capacity kW	6.39	5.57	5.09	4.36	3.59	2.97
	Input kW.	2.04	1.80	1.71	1.58	1.40	1.28
22°C	Capacity kW	6.34	5.51	5.01	4.30	3.53	2.92
	Input kW.	2.11	1.82	1.74	1.65	1.48	1.33

10. Electronic function

(Just for the 5K, 7K, 9K, 12K, 16K, 18K cooling and heating mode)

10.1 Electronic control working environment

Input voltage: 175~253V

Input power frequency: 50HZ

Ambient temperature: -7°C+43°C

Indoor fan normal working amp is less than 1A

Outdoor fan normal working amp is less than 1.5A

Four-way valve normal working amp is less than 1A

Swing motor: DC12V

Compressor: single-phase power supply. Its normal working amp is less than 15A

10.2 Proper symbols and their meaning

TA: Indoor ambient temperature

TE: Indoor evaporator temperature

TS: Setting temperature through the remote controller

I_{3sec}: Self-protection amp of compressor, continue three seconds until turns off the compressor.

I_{5MIN}: Self-protection amp of compressor, continue five minutes until turns off the compressor.

I_{FAN}: Self-protection amp of outdoor fan/indoor fans when they change from higher wind to lower wind.

I_{RESTORE}: Amp self-protection return value

TH_{DEFROST}: High wind, defrosting temperature difference

TM_{DEFROST}: Middle wind, defrosting temperature difference

TL_{DEFROST}: Low wind, defrosting temperature difference

TE1: Anti-cold wind, from Fan Off to Breeze temperature

TE2: Anti-cold wind, from Breeze to Setting Fan Speed temperature

TE3: Anti-cold wind, from Setting Fan Speed to Breeze temperature

TE4: Anti-cold wind, from Breeze to Fan Off temperature

TE5: Evaporator low temperature protection entering temperature

TE6: Evaporator low temperature protection restoring temperature

TE7: Evaporator high temperature protection, compressor off temperature

TE8: Evaporator high temperature protection, fan off temperature

TE9: Evaporator high temperature protection, restoring temperature

10.3 Function

Remote receiving

Testing and forced running

Position set for indoor unit wind vane

LED displaying and alarm

On or off Timer

Protection for the compressor

Current protection

High temperature protection of indoor heat exchanger at heating mode

Auto defrosting and heating recovery at heating mode

Anti cold air at heating mode

www.generalclimate.com

10.4 Protection

10.4.1 3 minutes delay at restart for compressor.

10.4.2 Sensor protection at open circuit and breaking disconnection

10.4.3 Fan Speed is out of control. When Indoor Fan Speed is too high (higher than High Fan+300RPM) or too low (lower than 400RPM), the unit stops and LED displays failure information and can't return to normal operation automatically.

10.4.4 Cross Zero signal error warning. If there is no Cross Zero signals in 4 minutes, the unit stops and LED displays failure information and can't return to normal operation automatically.

10.4.5 The current protection of the compressor

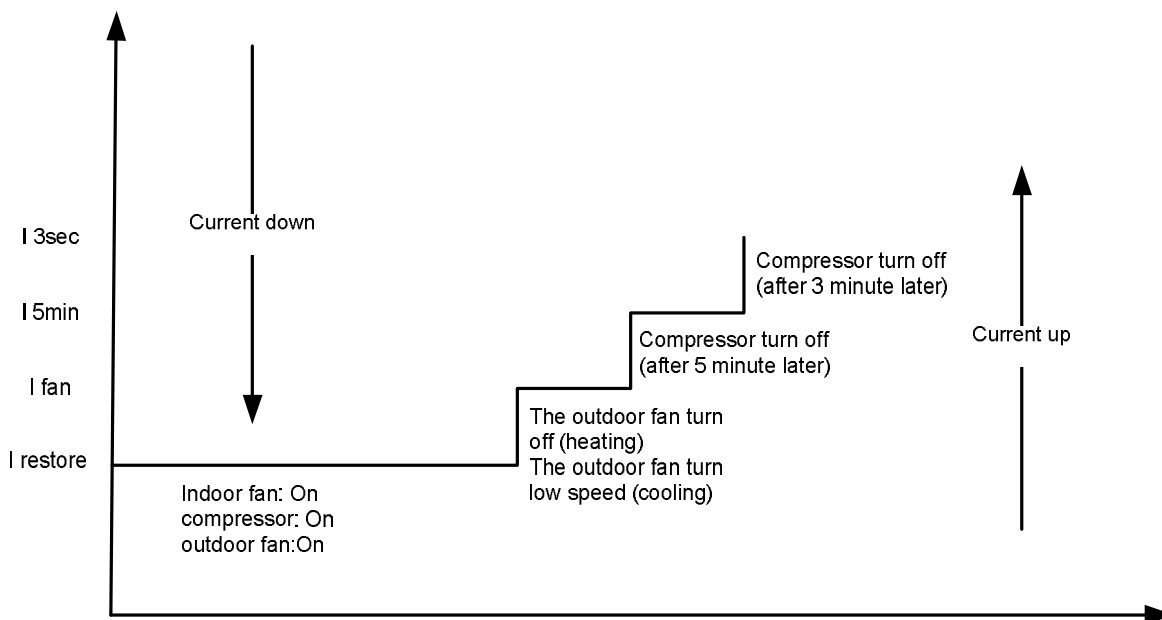

If compressor turns off for continuously 4 times due to current protection in 5 minutes from Compressor On, the unit stops and LED displays failure information and can't return to normal operation automatically.

10.5 Fan-only mode

Fan speed is high/mid/low/ Auto

10.6 Cooling mode

The 4-way valve is closed at cooling mode.

The action of the compressor and the outdoor fan: (T=indoor temperature)

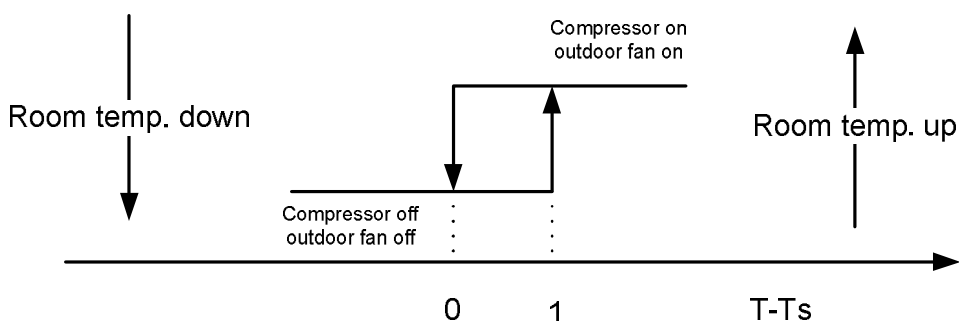

Auto fan at cooling mode:

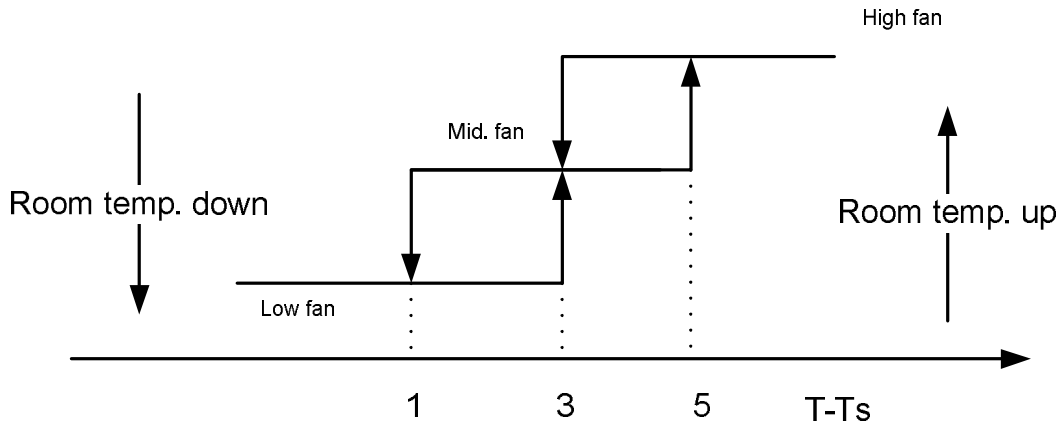

Anti-freezing control to indoor evaporator at cooling mode (T: evaporator temp.)

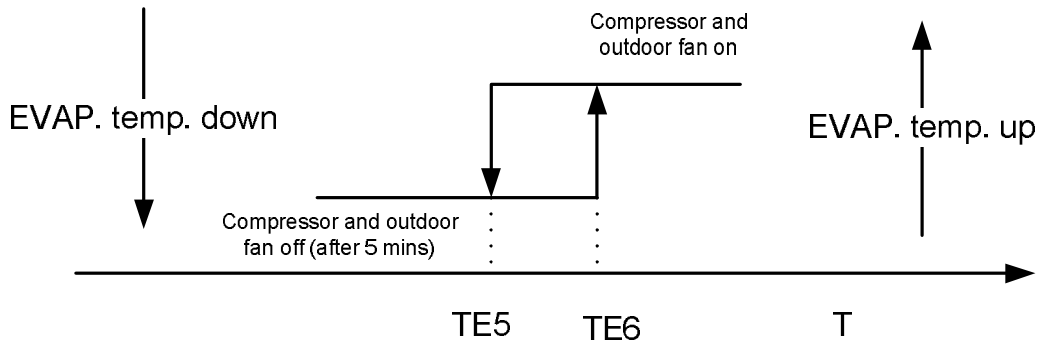

10.7 Dehumidifying mode

10.7.1 The 4-way valve is off in dehumidifying mode

10.7.2 Compressor and Indoor Fan actions in dehumidifying mode

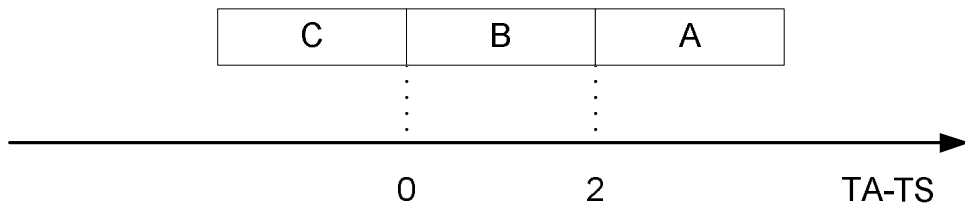

Block	Indoor Fan	Compressor and Outdoor Fan
A	LOW	ON 6minutes
	BREEZE	OFF 4minutes
B	LOW	ON 5minutes
	BREEZE	OFF 5minutes
C	LOW	ON 4minutes
	BREEZE	OFF 6minutes

Repeat on and off cycle.

10.7.3 Low room temperature protection:

When room temperature decreases to below 10°C, compressor and outdoor fan will stop(indoor fan is Breeze). Dehumidifying operation will be resumed when room temperature restores to over 13°C.

10.7.4 At dehumidifying mode, the anti-freezing function of the indoor heat exchanger is the same as that of cooling mode.

10.7.5 At dehumidifying mode, the action of fans of indoor is the same as that of air-only mode.

10.8 Heating mode

10.8.1 Generally, the 4-way valve is open in heating mode, but it is closed in defrosting mode.

4-way valve must delay 2 minutes compared with compressor if the compressor changed into non-heating mode or turned off. 4-way valve doesn't delay in dehumidifying mode

10.8.2 Generally, the outdoor fan is turned off with the on-off action of compressor in heating mode, except for the defrosting mode or the end of defrost

10.8.3 Action of compressor and outdoor fan motor at heating mode: compressor must run for 7 minutes after starting and then judge temperature. Meanwhile other protections are still valid.

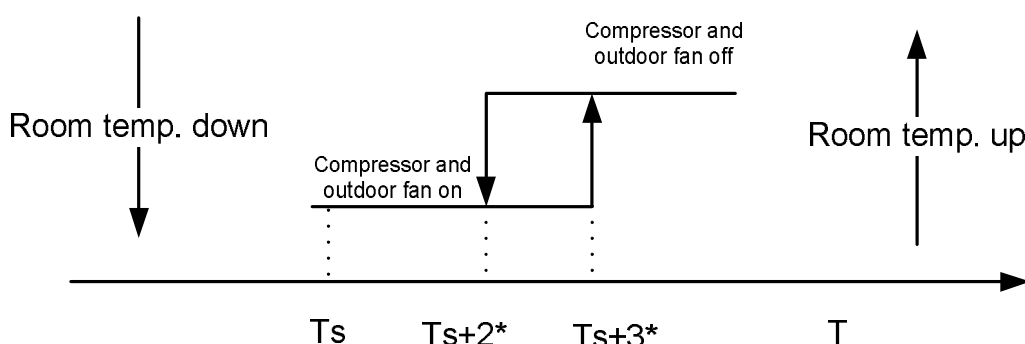

* This parameter can be changed from 0 to 3

10.8.4 Indoor Fan actions at heating mode

Indoor Fan can be set at HIGH/MID/LOW/AUTO by using a remote controller, but Anti-cold wind function prevails.

Anti-cold wind control function at heating mode (T=indoor exchanger temp.)

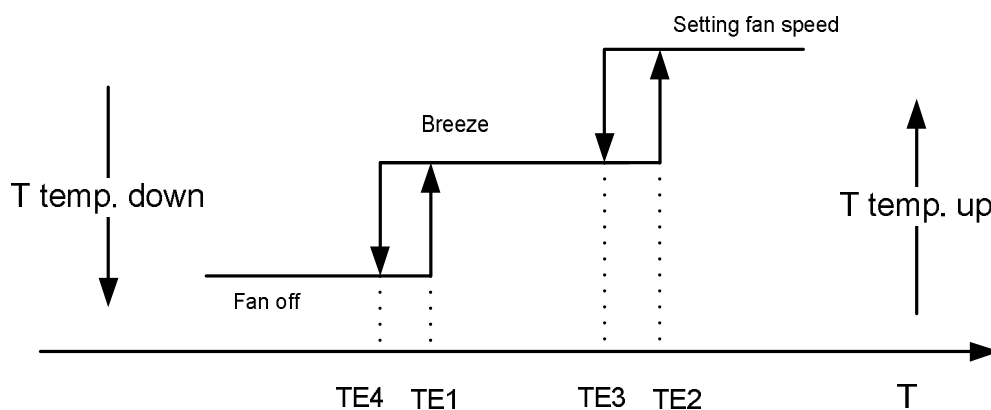

10.8.5 Auto wind at heating mode (T=indoor temp.)

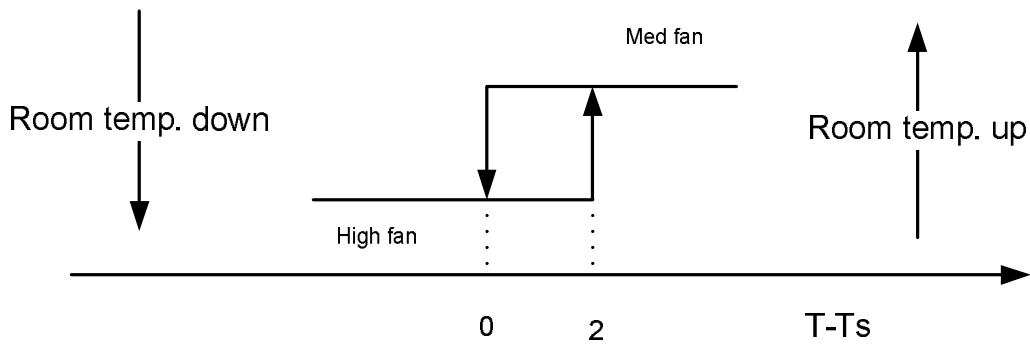

10.8.6 Indoor evaporator high-temperature protection at heating mode

(T=indoor exchanger temp.)

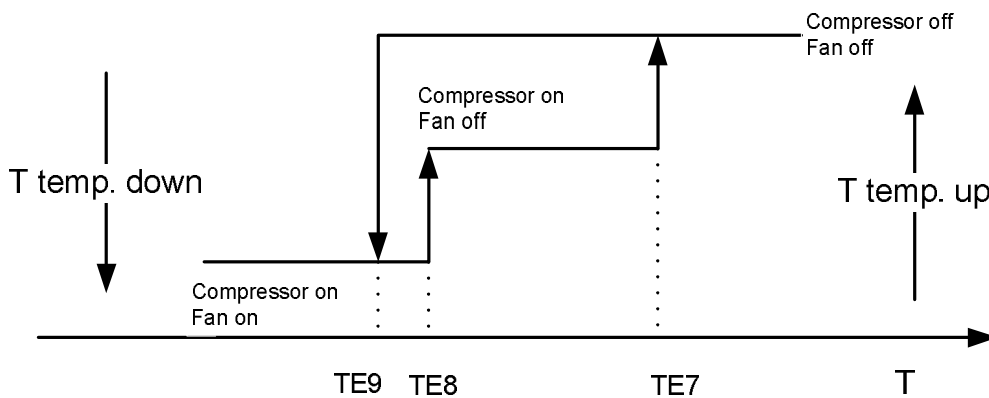

10.8.7 The louver opens to Standard Angle ANGLHEAT when power is on for the first time

10.9 Defrosting mode(available for heating mode)

Defrosting condition: Defrosting starts when either of the following ①&②:

① A and B are satisfied:

A: The compressor keeps running for 40 minutes or more.

B: The temperature difference of evaporator and room temperature meets one of the following:

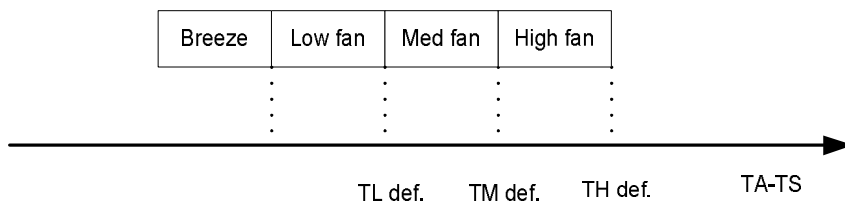

② Calculate from the end of latest defrost, evaporator high temp. Protection only closes outdoor fan with the compressor still running. Add up to 90 minutes.

Defrosting time

At condition ①, If item B is satisfied before item A, it would be regarded as severe frosting and the defrosting time is 10 minutes. If item B is satisfied after item A, the defrosting time is 6minutes.

At condition ②, the defrosting time is 10 minutes.

After three times continuous 6-minute defrost, the fourth defrost time should be 10 minutes.

The circulation is as following:

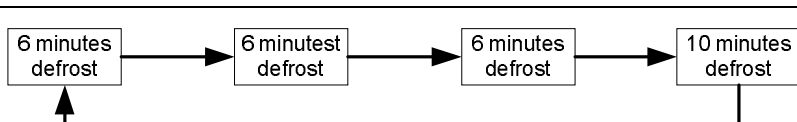

Ending condition of defrosting

If one of following conditions is satisfied, end the defrost and turn into heating mode:

A. The defrost time has reached to 6 or 10 minutes.

B. The compressor current has reached to $I_{DEFROST}$ or above, $I_{DEFROST}$ differs in different models

Defrosting Actions

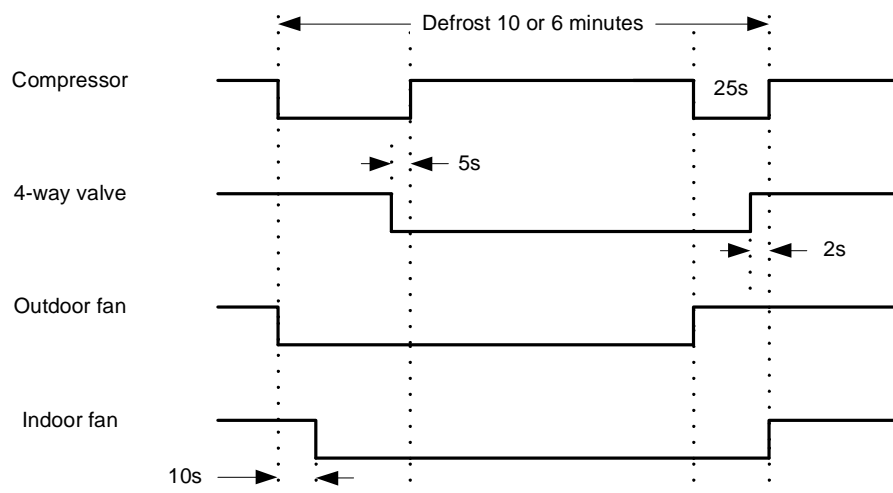

10.10 Auto mode

10.10.1 The air conditioner automatically selects one of the following operation modes: cooling, heating or fan only according to the temperature difference between room temperature (TA) and set temperature (TS).

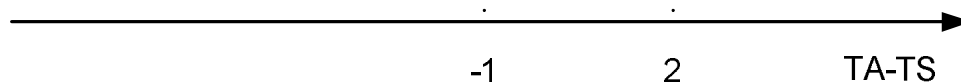
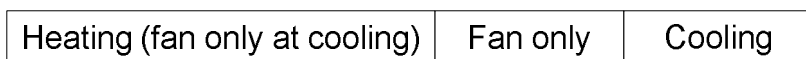

10.10.2 The indoor fan blows automatically in corresponding selected mode

10.10.3 The motion of indoor fan's blade should accord with the selected operation mode

10.10.4 One mode should be carried out for at least 15 minutes once selected. If the compressor cannot start for 15 minutes, reselect the operation mode according to the room temp. and set temp., or reselect when the set temp. varies

10.11 Force cooling function

10.11.1 Select forced cooling function with the forced cooling button or the switch

10.11.2 The compressor is unconditionally turned on, after 30 minutes cooling operation

whose fan mode is set as low, the A/C operates at the DRY mode with a set temp. of 24°C

10.11.3 All protections of remote control cooling are available at forced cooling operation

10.11.4 Forced Auto function

Select forced auto function with the forced auto button or the switch.

In forced auto status the A/C operates at remote control mode with a set temp. of 24°C

10.12 Sleep mode

10.12.1 The sleep function is available at cooling, heating or auto mode

10.12.2 Cooling:

The set temperature rise 1°C per hour. Two hours later, the set temperature will maintain as a constant and the fan speed is kept at low speed.

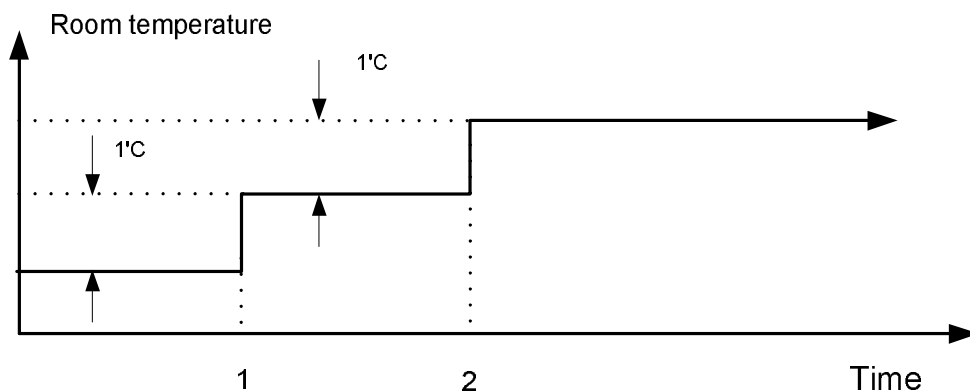

10.12.3 Heating:

The set temperature decrease 1°C per hour. Two hours later, the set temperature will maintain as a constant and the air circulation is kept at low speed (Anti-cold function takes precedence over all).

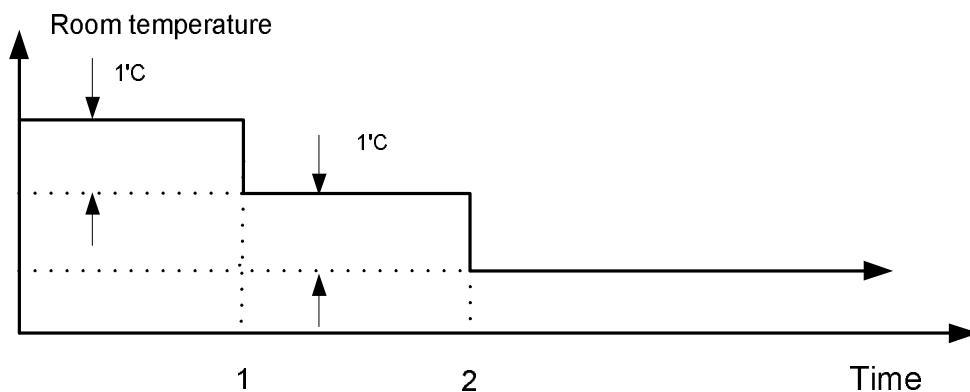

10.12.4 Auto:

After an hour running under economic mode, the set temp will rise 1°C, if it is under cooling mode; the set temp will decrease 1°C, if it is under heating mode; the set temp will be changeless, if it is under fan-only mode; the condition will be the same after the air conditioner running under economic mode after 2 hours, and during the next time the set temp do not change. The total time is 7 hours, after 7 hours the unit stops.

10.13 Auto restart function

In case of a sudden power failure, this function automatically sets the unit to previous settings before the power failure when power returns

10.14 Anion (optional)

Starts with indoor fan.

11. Model and Parameters

Model	GC/GU-S05CR	GC/GU-S07HR	GC/GU-S09HR	GC/GU-S12HR	GC/GU-S18HR
I3SEC [A]	8,5	8,5	10	11	16
I5MIN [A]	6,2	6,2	7,5	10	13
IFAN [A]	5,2	5,2	5,5	8	11
IRESTORE [A]	4,2	4,2	4.5A	6	9,5
IDEFROST [A]		3,2	3,5	5,5	6,5
TE1 [°C]		28	28	28	34
TE2 [°C]		32	32	32	36
TE3 [°C]		30	30	30	30
TE4 [°C]		26	26	20	20
TE5 [°C]	2	2	2	3	3
TE6 [°C]	7	7	7	8	10
TE7 [°C]		60	60	60	60
TE8 [°C]		53	53	53	52
TE9 [°C]		50	50	50	50
ANGLCOOL [°]	200°	200°	200°	200°	50°
ANGLHEAT [°]		0°	0°	0°	105°
ANGLOFF [°]	124°	124°	124°	124°	0°
TH _{DEFROST} [°C]		16° C	14° C	14° C	17° C
TM _{DEFROST} [°C]		17° C	15° C	15° C	18° C
TL _{DEFROST} [°C]		18° C	16° C	16° C	19° C

12. Troubleshooting

12.1 Display board

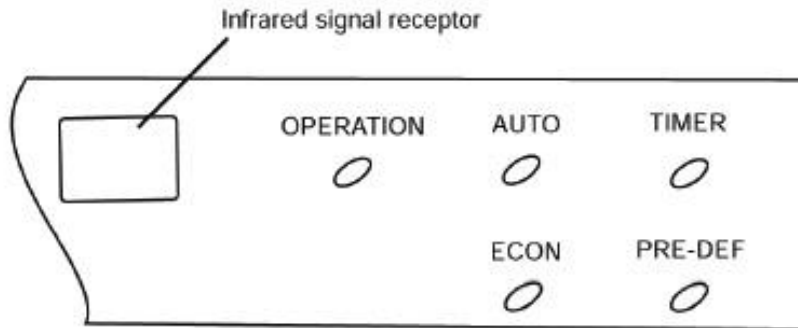

§ Operation

The indicator flashes once every second after power is on and illuminates when the air conditioner is in operation.

§ Timer indicator:

The indicator illuminates then TIMER is set ON.

§ PRE-DEF. indicator (For cooling & heating mode only)

The air conditioner starts defrosting automatically if outdoor unit frosts in heating operating.

At this time, PRE-DEF. indicator illuminates.

§ Auto indicator:

This indicator flashes when the air conditioner is in AUTO operation.

§ ECON indicator

This indicator illuminates while the air conditioner is in economic operation.

12.2 Troubleshooting

For cooling mode:

Failure phenomenon	Operation lamp	Timer lamp
Indoor fan speed has been out of control for over 1 minute	☆	X
Indoor room temp. or evaporator sensor is open circuit or short circuit	☆	On
Over current protection of the compressor occurs 4 times	X	☆
EEROM error	On	☆
No over-zero signal	☆	☆

┐ Extinguish

☆ Flash at 5Hz

For heat pump mode:

Failure phenomenon	Operation lamp	Timer lamp	Defrosting lamp
Over current protection of the compressor occurs 4 times	☆	X	☆
Indoor fan speed has been out of control for over 1 minute	X	☆	☆
No over-zero signal	☆	☆	☆
Temp. sensor on indoor evaporator is open circuit or short circuit	X	X	☆
Indoor room temp. sensor is open circuit or short circuit	X	☆	X
EEROM error	On	☆	X

┐ Extinguish

☆ Flash at 5Hz

12.3 Diagnostic chart

After energizing, no indicator is lighted and the air conditioner can't be operated.

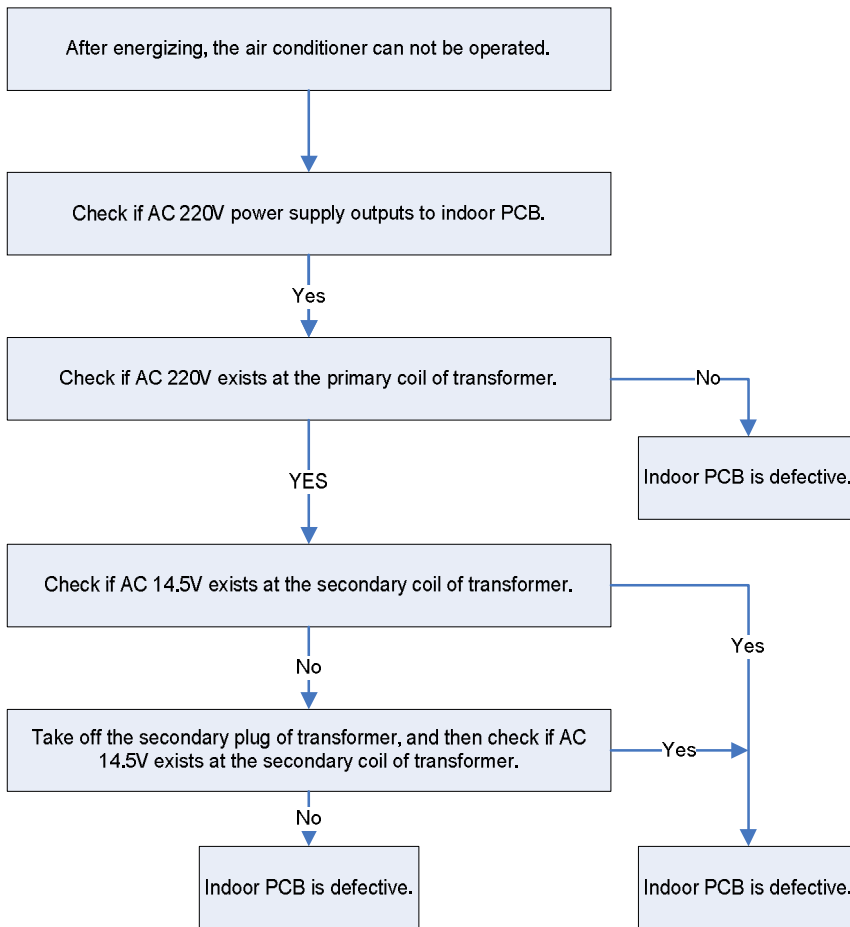

12.4 Resetting phenomenon often occurs during operation.

(That is automatically entering to the status when power is on.)

The reason is that the instantaneous voltage of main chip is less than 4.5V. Check according to the following procedure:

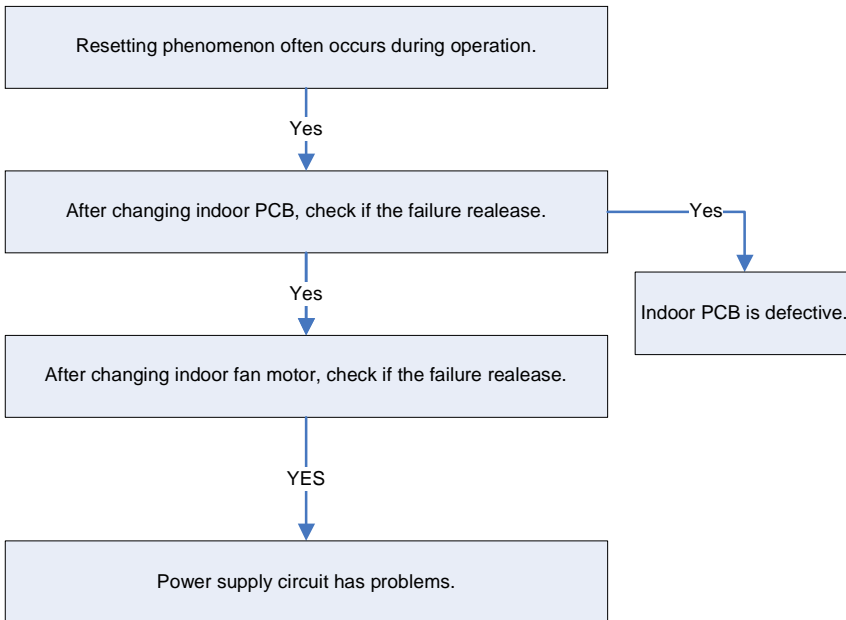

12.5 Operation lamp flashes and Timer lamp off.

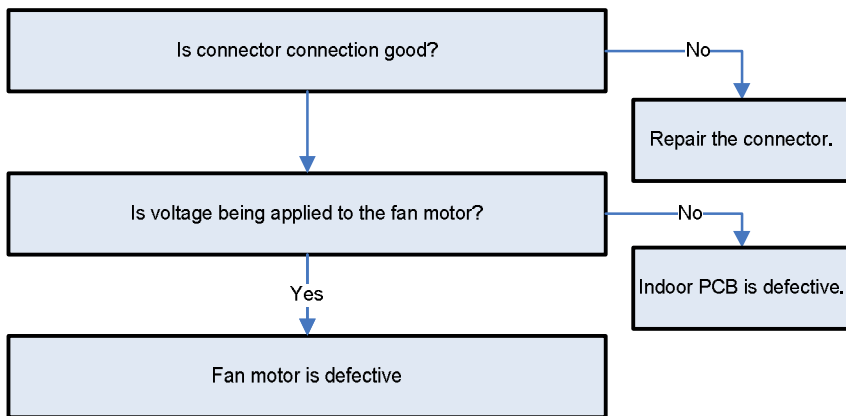

12.6 Operation lamp flashes and Timer lamp on.

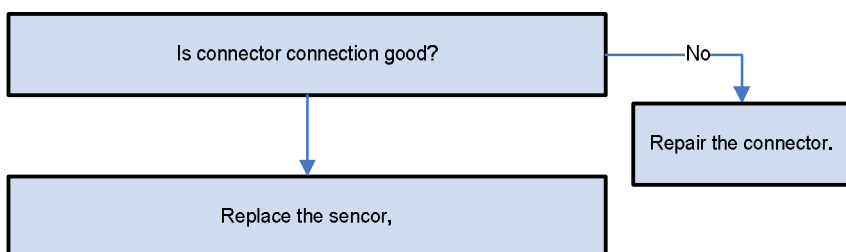

12.7 Operation lamp off and Timer lamp flashes

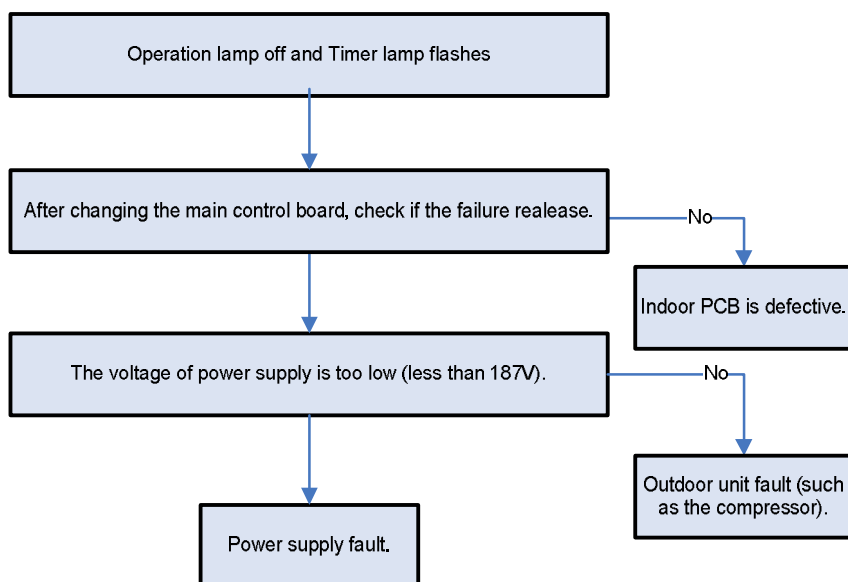

12.8 Operation lamp on and Timer lamp flashes

EEROM error, indoor PCB is defective.

12.9 Operation lamp flashes, Timer lamp flashes .

This is alarm signal when the main chip can't detect over-zero signal. When such failure occurs, the main control board must have fault.

13. Characteristic of temperature sensor

Temp.°C	Resistance KΩ	Temp.°C	Resistance KΩ	Temp.°C	Resistance KΩ
-10	62.2756	17	14.6181	44	4.3874
-9	58.7079	18	13.918	45	4.2126
-8	56.3694	19	13.2631	46	4.0459
-7	52.2438	20	12.6431	47	3.8867
-6	49.3161	21	12.0561	48	3.7348
-5	46.5725	22	11.5	49	3.5896
-4	44	23	10.9731	50	3.451
-3	41.5878	24	10.4736	51	3.3185
-2	39.8239	25	10	52	3.1918
-1	37.1988	26	9.5507	53	3.0707
0	35.2024	27	9.1245	54	2.959
1	33.3269	28	8.7198	55	2.8442
2	31.5635	29	8.3357	56	2.7382
3	29.9058	30	7.9708	57	2.6368
4	28.3459	31	7.6241	58	2.5397
5	26.8778	32	7.2946	59	2.4468
6	25.4954	33	6.9814	60	2.3577
7	24.1932	34	6.6835	61	2.2725
8	22.5662	35	6.4002	62	2.1907
9	21.8094	36	6.1306	63	2.1124
10	20.7184	37	5.8736	64	2.0373
11	19.6891	38	5.6296	65	1.9653
12	18.7177	39	5.3969	66	1.8963
13	17.8005	40	5.1752	67	1.83
14	16.9341	41	4.9639	68	1.7665
15	16.1156	42	4.7625	69	1.7055
16	15.3418	43	4.5705	70	1.6469

Exploded View Parts for Model : GC-S05CR 220-240V~,50Hz :Indoor unit

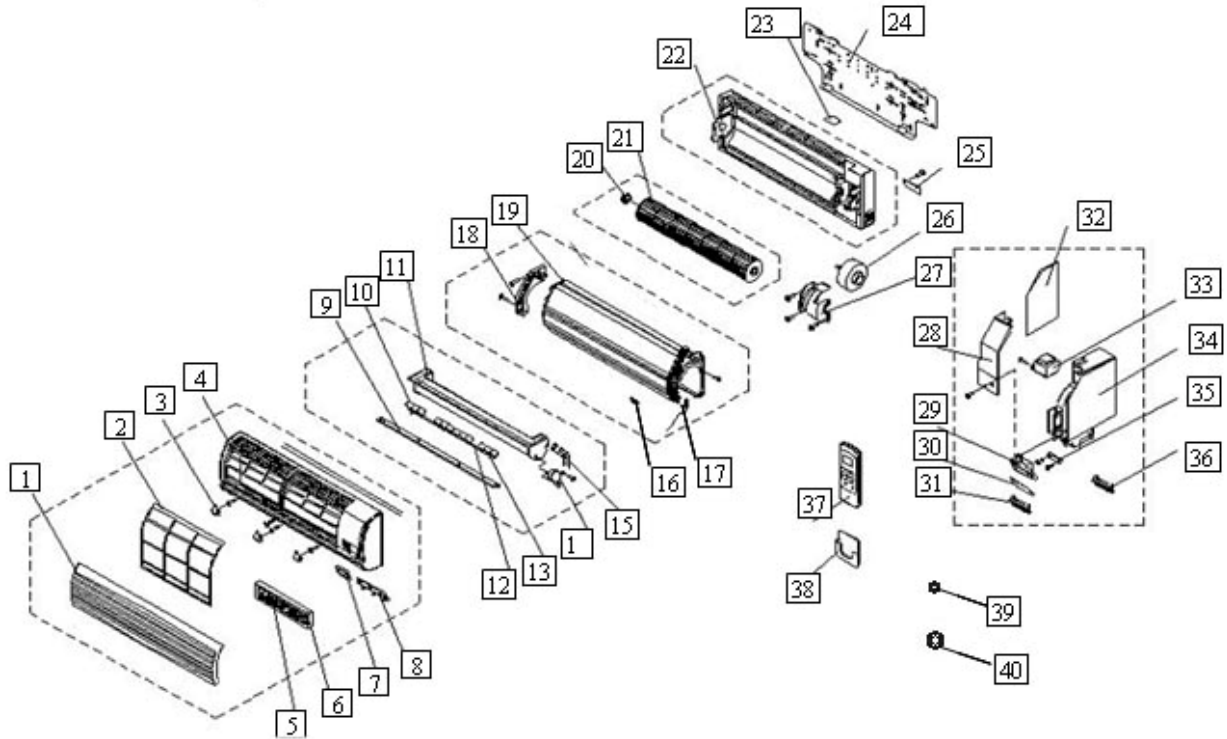

No.	Part Name	Quantity	Sale code
1	Front Panel	1	10309121201
2	Air Filter	2	10309121202
3	Screw cap	3	10309121203
4	Panel frame	1	10309121204
5	Air cleaner	1	10109121226
6	Air cleaner holder	1	10109121225
7	Window for receiver	1	10309121207
8	Indicator for LED	1	10309121208
9	Horizontal louver	1	10309121209
10	Vertical louver	12	10309121210
11	Air out frame	1	10309121211
12	Louver holder	1	10309121212
13	Louver rocker	1	10309121213
	Rocker gasket	1	10309121214
14	Louver motor	1	10121121218
15	Drain hose	1	10109121215
16	Indoor temp sensor	1	10109121243
17	Evaporator temp sensor	1	10109121242

18	Left holder for evaporator	1	10307111202
19	Evaporator	1	10305111201
20	Bearing holder	1	10309121220
21	Cross flow fan, assy	1	10309121221
22	Chassis	1	10309121222
23	Back cover for chassis	1	10309121223
24	Installation Plate	1	10909121002
25	Connecting pipe clamp	1	10309121225
26	Fan motor	1	10309121226
27	Motor cover	1	10309121227
28	E-part box cover	1	10309121228
29	Indicator holder	1	10309121229
30	Display board , Ass'y	1	10407111002
31	Display board enclosure	1	10309121231
32	Main control board	1	10305111001
33	Transformer	1	10718121006
34	E-Parts box	1	10718121007
35	Wire clamp	1	10112121234
36	Wire joint, 5p	1	10407111004
37	Remote Controller	1	10109111203
38	Holder, Remote Controller	1	10109121208
39	Copper nut, TLM-A01	1	10909121012
40	Copper nut, TLM-B02	1	10909121013

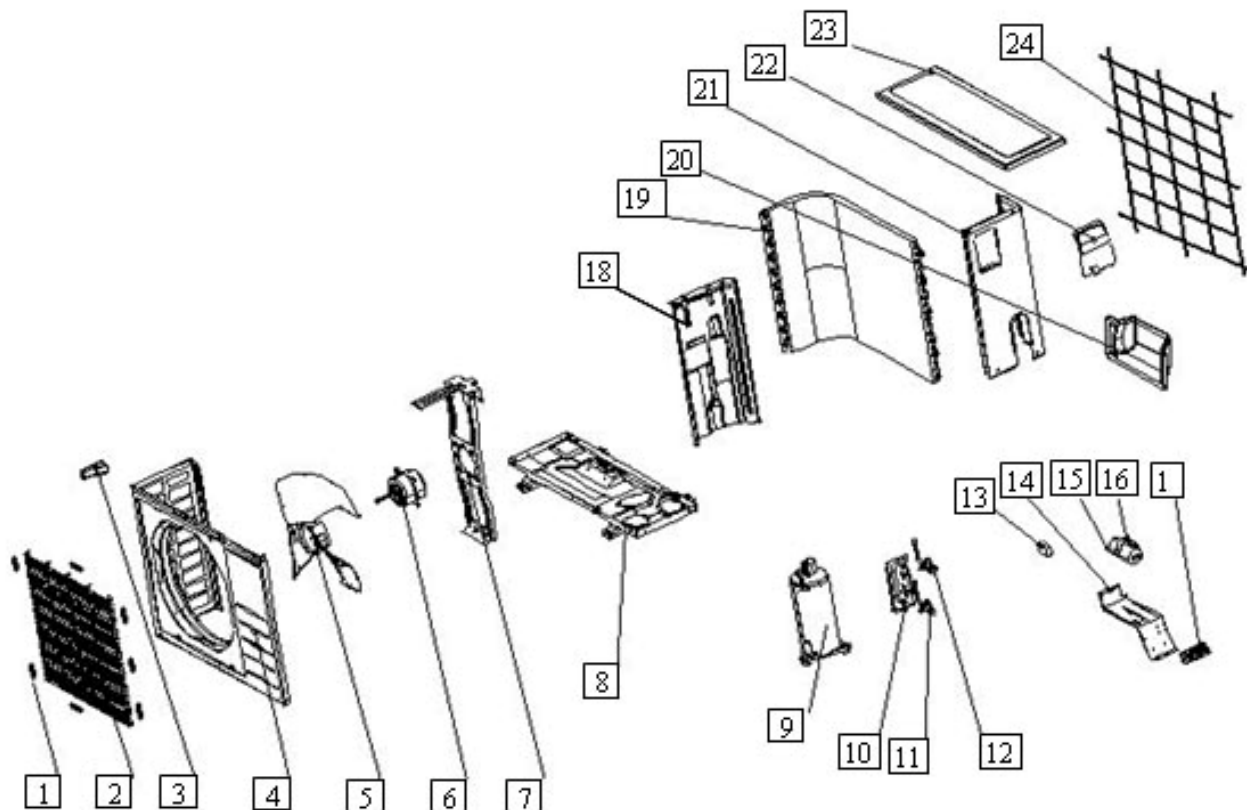

No.	Part Name	Quantity	Sale code
1	Clamp for front net	6	10112121801
2	Front net	1	10109121801
3	Small Handle	1	10109121802
4	Front clapboard	1	10107121801
5	Propeller fan	1	10109121804
6	Fan Motor	1	10109121805
7	Holder for fan motor	1	10109121806
8	Chassis	1	10105121802
9	Compressor	1	10105121801
10	Installation plate for valves	1	10309121809
11	Gas pipe valve	1	10309121810
12	Liquid pipe valve	1	10309121811
13	Fan motor capacitor	1	10109121819
14	Installation board for E-parts	1	10109121820
15	Compressor capacitor	1	10105121803
16	Capacitor clamp	1	10109121822
17	Wire joint	1	10109111802

18	Separating board	1	10109121813
19	Condenser	1	10107111803
20	Water collector	1	10109121815
21	Right clapboard	1	10109121816
22	Big Handle	1	10109121817
23	Cover	1	10109121818
24	Rear Net	1	10109121824

Exploded View Parts for Model : GC-S07HR 220-240V~,50Hz :Indoor Unit

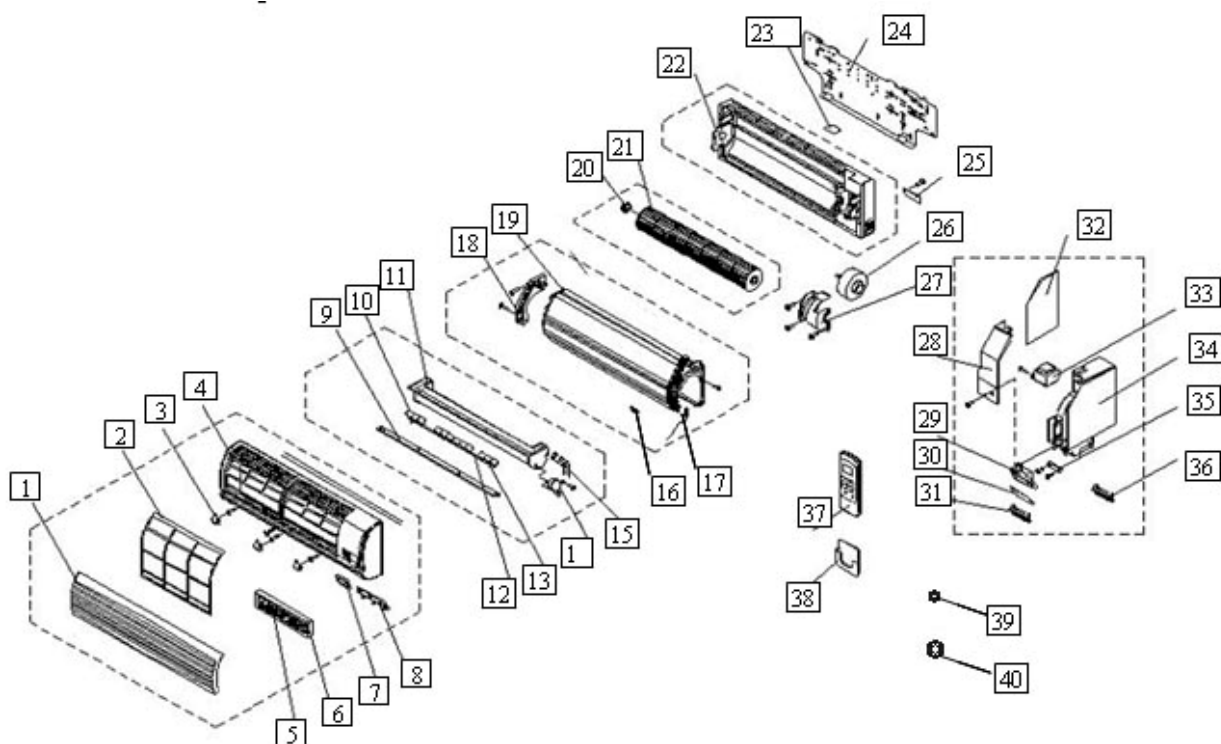

No.	Part Name	Quantity	Sale code
1	Front Panel	1	10309121201
2	Air Filter	2	10309121202
3	Screw cap	3	10309121203
4	Panel frame	1	10309121204
5	Air cleaner	1	10109121226
6	Air cleaner holder	1	10109121225
7	Window for receiver	1	10309121207
8	Indicator for LED	1	10309121208
9	Horizontal louver	1	10309121209

10	Vertical louver	12	10309121210
11	Air out frame	1	10309121211
12	Louver holder	1	10309121212
13	Louver rocker	1	10309121213
	Rocker gasket	1	10309121214
14	Louver motor	1	10121121218
15	Drain hose	1	10109121215
16	Indoor temp sensor	1	10109121243
17	Evaporator temp sensor	1	10109121242
18	Left holder for evaporator	1	13008111007
19	Evaporator	1	13008111008
20	Bearing holder	1	10309121220
21	Cross flow fan, assy	1	10309121221
22	Chassis	1	10309121222
23	Back cover for chassis	1	10309121223
24	Installation Plate	1	10909121002
25	Connecting pipe clamp	1	10309121225
26	Fan motor	1	10309121226
27	Motor cover	1	10309121227
28	E-part box cover	1	10309121228
29	Indicator holder	1	10309121229
30	Display board , Ass'y	1	10309121240
31	Display board enclosure	1	10309121231
32	Main control board	1	10307121001
33	Transformer	1	10718121006
34	E-Parts box	1	10718121007
35	Wire clamp	1	10112121234
36	Wire joint, 5p	1	10309121242
37	Remote Controller	1	10109121207
38	Holder, Remote Controller	1	10109121208
39	Copper nut, TLM-A01	1	10909121012
40	Copper nut, TLM-B02	1	10909121013

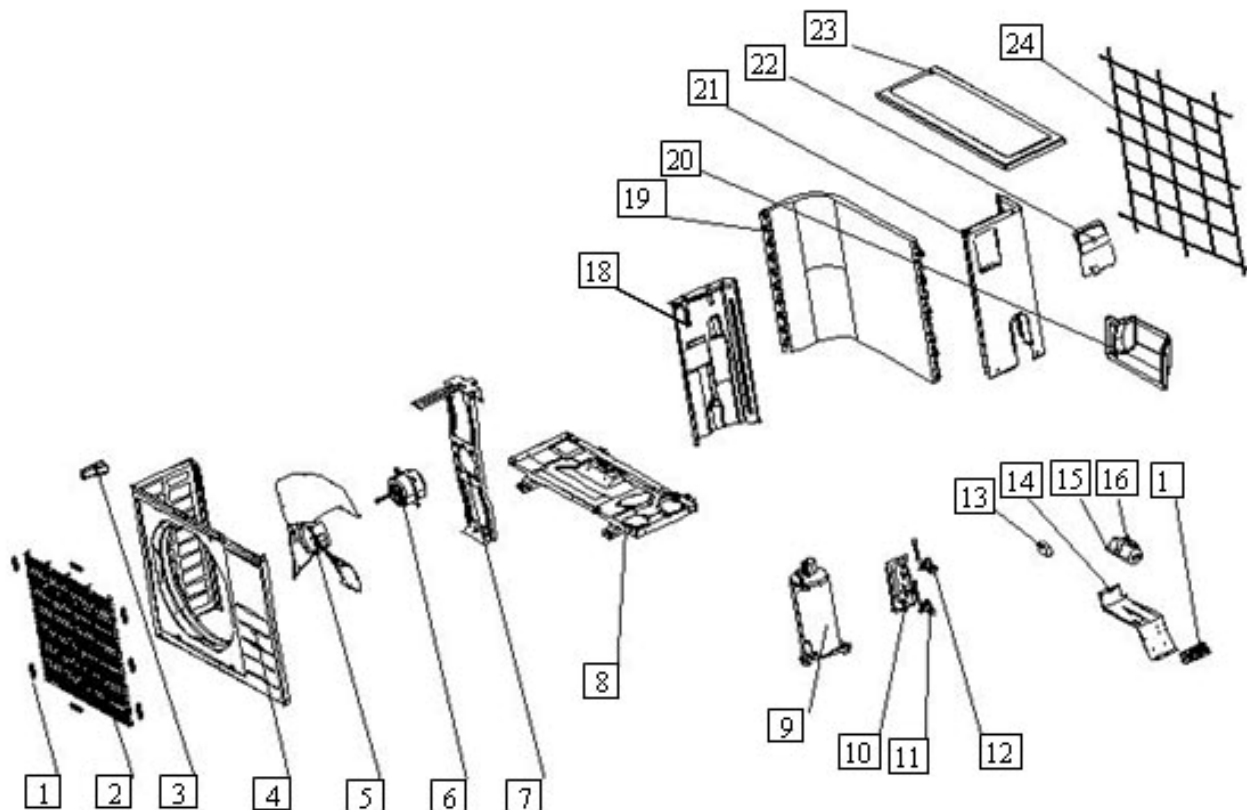

No.	Part Name	Quantity	Sale code
1	Clamp for front net	6	10112121801
2	Front net	1	10109121801
3	Small Handle	1	10109121802
4	Front clapboard	1	10107121801
5	Propeller fan	1	10109121804
6	Fan Motor	1	10109121805
7	Holder for fan motor	1	10109121806
8	Chassis	1	10107121803
9	Compressor	1	10107121802
10	Installation plate for valves	1	10309121809
11	Gas pipe valve	1	10309121810
	4-way valve	1	10109121812
12	Liquid pipe valve	1	10309121811
13	Fan motor capacitor	1	10109121819
14	Installation board for E-parts	1	13009111005
15	Compressor capacitor	1	10309121820
16	Capacitor clamp	1	10109121822

17	Wire joint	1	10109121823
18	Separating board	1	10109121813
19	Condenser	1	10107121804
20	Water collector	1	10109121815
21	Right clapboard	1	10109121816
22	Big Handle	1	10109121817
23	Cover	1	10109121818
24	Rear Net	1	10109121824

Exploded View Parts for Model : GC-S09HR 220-240V~,50Hz :Indoor Unit

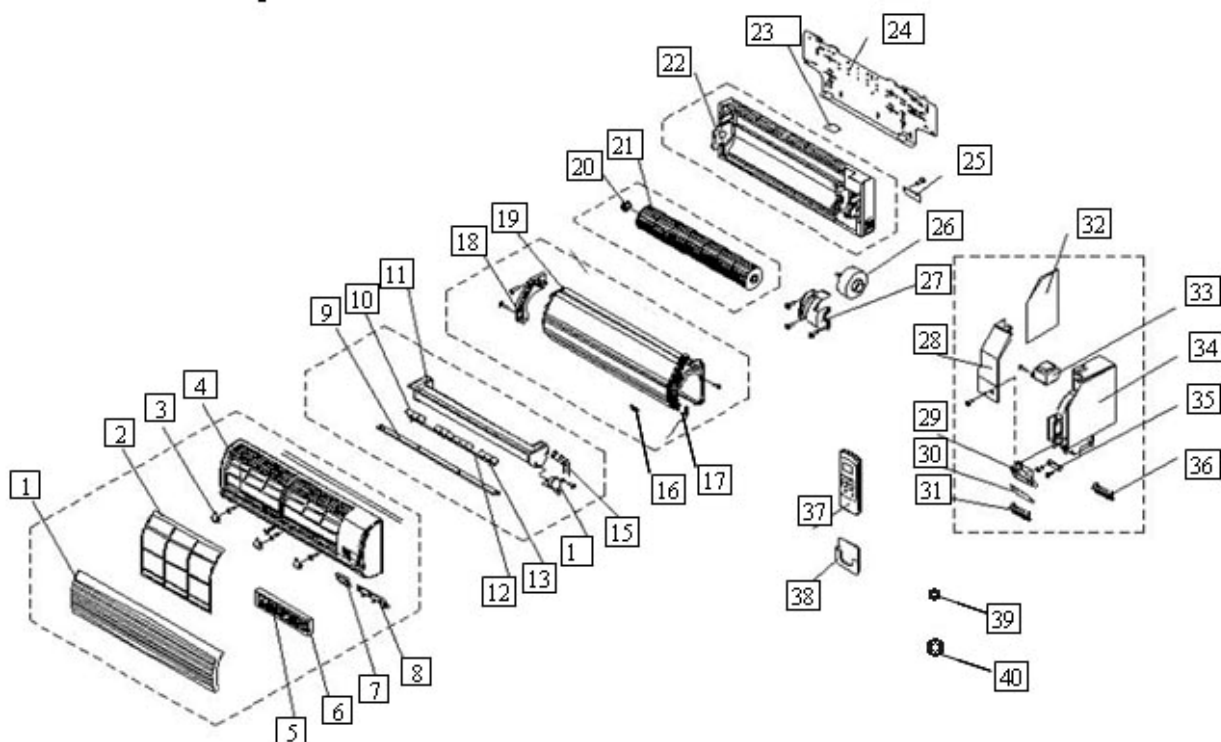

No.	Part Name	Quantity	Sale code
1	Front Panel	1	10309121201
2	Air Filter	2	10309121202
3	Screw cap	3	10309121203
4	Panel frame	1	10309121204
5	Air cleaner	1	10109121226
6	Air cleaner holder	1	10109121225
7	Window for receiver	1	10309121207
8	Indicator for LED	1	10309121208
9	Horizontal louver	1	10309121209

10	Vertical louver	12	10309121210
11	Air out frame	1	10309121211
12	Louver holder	1	10309121212
13	Louver rocker	1	10309121213
	Rocker gasket	1	10309121214
14	Louver motor	1	10121121218
15	Drain hose	1	10109121215
16	Indoor temp sensor	1	10109121243
17	Evaporator temp sensor	1	10109121242
18	Left holder for evaporator	1	13008111007
19	Evaporator	1	13009111002
20	Bearing holder	1	10309121220
21	Cross flow fan, assy	1	10309121221
22	Chassis	1	10309121222
23	Back cover for chassis	1	10309121223
24	Installation Plate	1	10909121002
25	Connecting pipe clamp	1	10309121225
26	Fan motor	1	10309121226
27	Motor cover	1	10309121227
28	E-part box cover	1	10309121228
29	Indicator holder	1	10309121229
30	Display board , Ass'y	1	10309121240
31	Display board enclosure	1	10309121231
32	Main control board	1	10309121241
33	Transformer	1	10718121006
34	E-Parts box	1	10718121007
35	Wire clamp	1	10112121234
36	Wire joint, 5p	1	10309121242
37	Remote Controller	1	10109121207
38	Holder, Remote Controller	1	10109121208
39	Copper nut, TLM-A01	1	10909121012
40	Copper nut, TLM-B02	1	10909121013

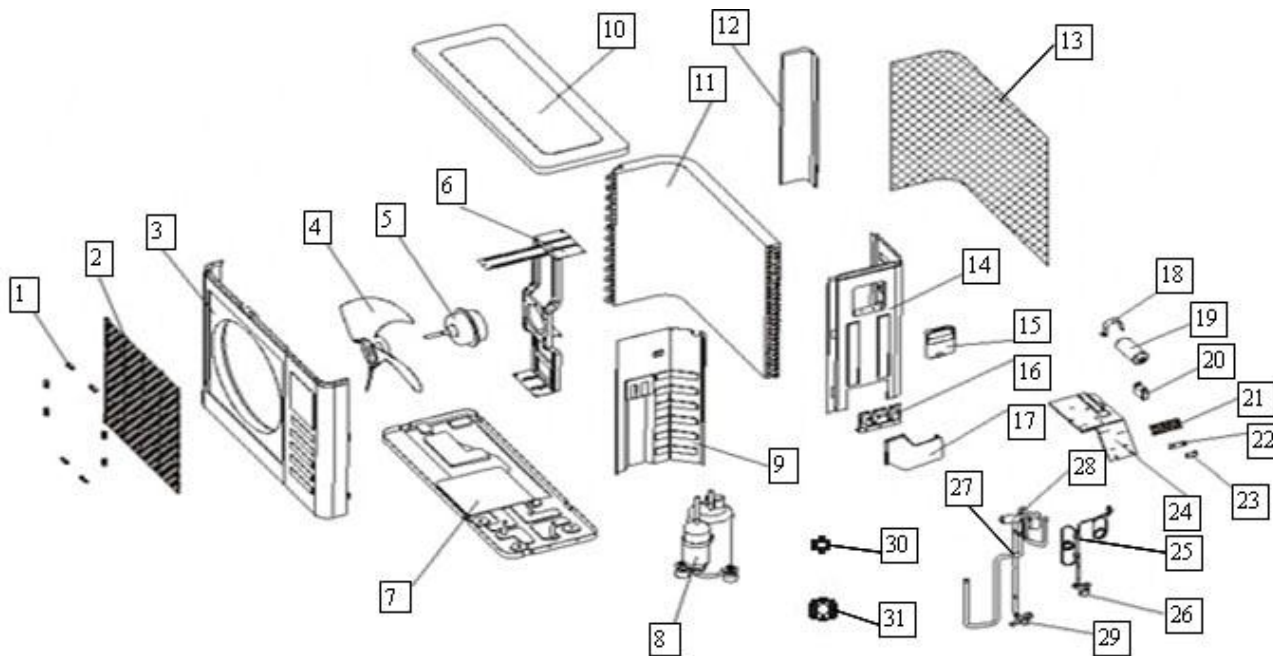

No.	Part Name	Quantity	SALE Code
1	Clamp for front net	6	10112121801
2	Front net	1	10109121801
3	Front clapboard	1	10109113801
4	Propeller fan	1	10109121804
5	Fan Motor	1	20407111802
6	Holder for fan motor	1	10109121806
7	Chassis	1	10107123802
8	Compressor	1	50309121805
9	Separating board	1	13008111803
10	Cover	1	11609121807
11	Condenser	1	11609121801
12	Installation board , Left	1	11609121804
13	Rear Net	1	11609121808
14	Right clapboard	1	11607111801
15	Big Handle	1	10109121817
16	Installation plate for valves	1	10309121809
17	Water collector	1	10109121815
18	Capacitor Clamp	1	10109121822
19	Compressor capacitor	1	11812113811
20	Fan motor capacitor	1	10112121815
21	Wire joint	1	10109121823

22	Washer for wire joint	1	10112121817
23	Wire Clamp	1	10112121816
24	Installation board for E-parts	1	13009111005
25	Low Pressure Valve Ass'y	1	11608121806
26	4-Ways valve	1	10109121812
27	Gas pipe valve	1	10309121810
28	High Pressure Valve Ass'y	1	10309121821
29	Liquid pipe valve	1	10309121811
30	Copper nut, TLM-A01	1	10909121012
31	Copper nut, TLM-B02	1	10909121013

Exploded View Parts for Model : GC-S12HR 220-240V~,50Hz :Indoor Unit

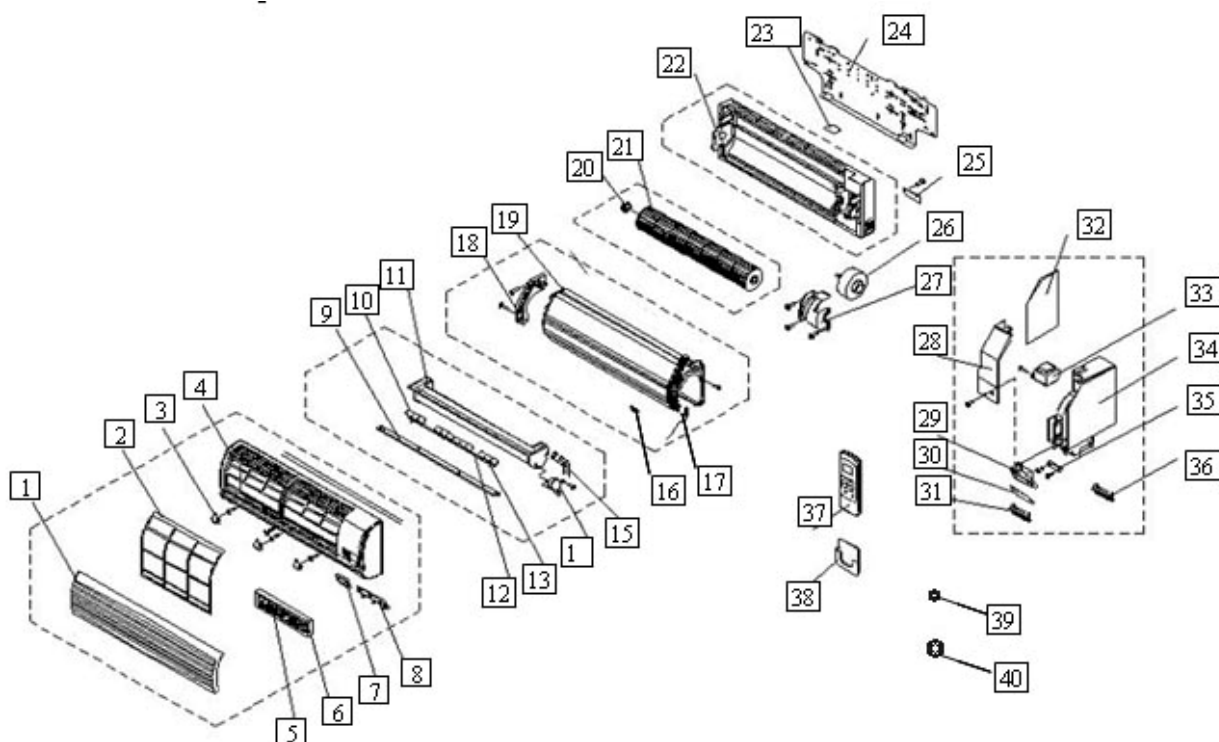

No.	Part Name	Quantity	Sale code
1	Front Panel	1	10309121201
2	Air Filter	2	10309121202
3	Screw cap	3	10309121203
4	Panel frame	1	10309121204
5	Air cleaner	1	10109121226
6	Air cleaner holder	1	10109121225
7	Window for receiver	1	10309121207
8	Indicator for LED	1	10309121208

9	Horizontal louver	1	10309121209
10	Vertical louver	12	10309121210
11	Air out frame	1	10309121211
12	Louver holder	1	10309121212
13	Louver rocker	1	10309121213
	Rocker gasket	1	10309121214
14	Louver motor	1	10121121218
15	Drain hose	1	10109121215
16	Indoor temp sensor	1	10109121243
17	Evaporator temp sensor	1	10109121242
18	Left holder for evaporator	1	13008111007
19	Evaporator	1	13012111001
20	Bearing holder	1	10309121220
21	Cross flow fan, assy	1	10309121221
22	Chassis	1	10309121222
23	Back cover for chassis	1	10309121223
24	Installation Plate	1	10909121002
25	Connecting pipe clamp	1	10309121225
26	Fan motor	1	10309121226
27	Motor cover	1	10309121227
28	E-part box cover	1	10309121228
29	Indicator holder	1	10309121229
30	Display board , Ass'y	1	10309121240
31	Display board enclosure	1	10309121231
32	Main control board	1	10312121254
33	Transformer	1	10718121006
34	E-Parts box	1	10718121007
35	Wire clamp	1	10112121234
36	Wire joint, 5p	1	10309121242
37	Remote Controller	1	10109121207
38	Holder, Remote Controller	1	10109121208
39	Copper nut, TLM-A01	1	10909121012
40	Copper nut, TLM-C03	1	10912121019

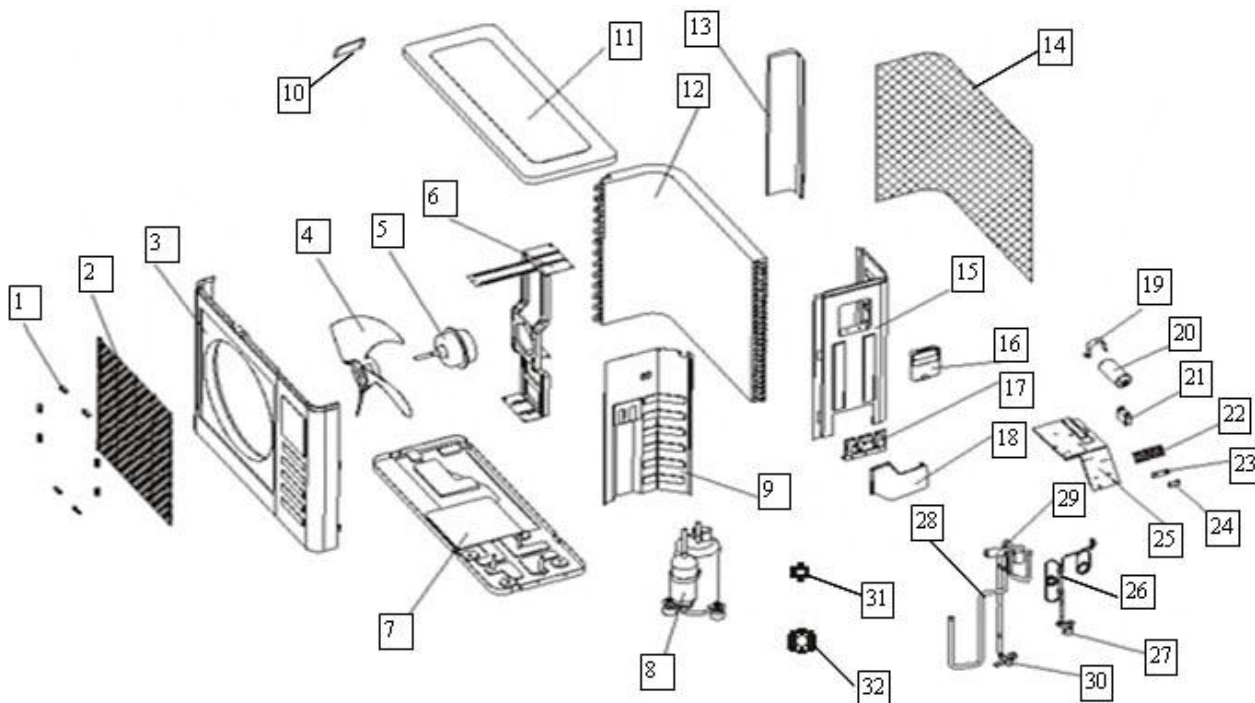

No.	Part Name	Quantity	Sale code
1	Clamp for front net	6	10112121801
2	Front net	1	10109121801
3	Front clapboard	1	13012111801
4	Propeller fan	1	10112121803
5	Fan motor	1	10112111801
6	Holder for fan motor	1	50312121801
7	Chassis	1	11612121801
8	Compressor	1	10112121821
9	Separating board	1	10116113813
10	Small Handle	1	10830121811
11	Cover	1	13012111805
12	Condenser	1	11612121803
13	Installation board , left	1	13012111803
14	Rear net	1	13012111806
15	Right clapboard	1	13012111808
16	Big handle	1	10112121808
17	Installation plate for valves	1	10118113805
18	Water collector	1	10118121832
19	Capacitor clamp	1	10112121814
20	Compressor capacitor	1	30324313020

21	Fan motor capacitor	1	10112121815
22	Wire joint	1	10109121823
23	Washer for wire joint	1	10112121817
24	Clamp for wiring	1	10112121816
25	Installation board for E-parts	1	15009111801
26	High Pressure Valve Ass'y	1	13012121801
27	Liquid pipe valve	1	10118121830
28	Low pressure Valve Ass'y	1	13012121802
29	4-ways valve	1	10312121852
30	Low-pressure Valve	1	10312121858
31	Copper nut, TLM-A01	1	10909121012
32	Copper nut, TLM-B02	1	10912121019

Exploded View Parts for Model GC-S18HR 220-240V~,50Hz : Indoor Unit

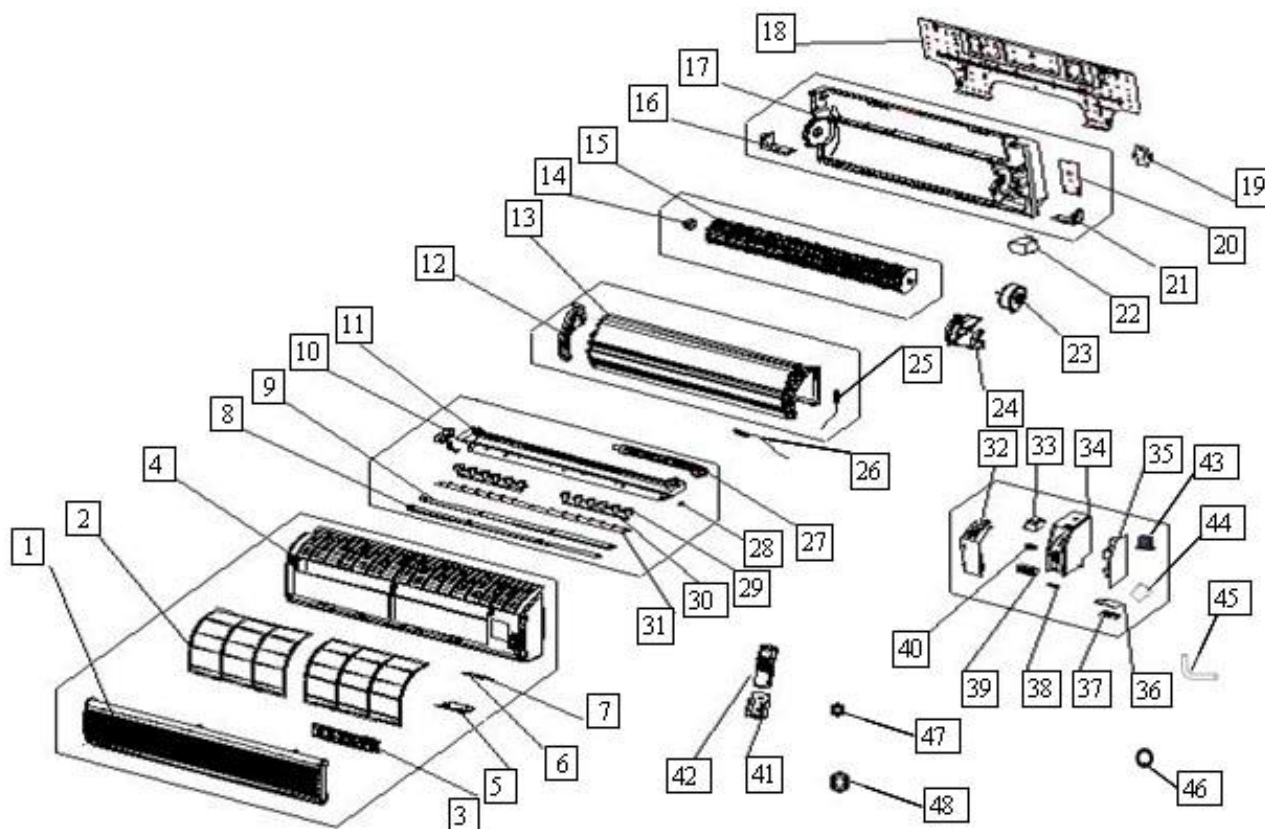

No.	Part Name	Quantity	Sale code
1	Front panel	1	10318121201
2	Air filter	2	10318121202
3	Air cleaner	1	10109121226
	Air cleaner holder	1	10109121225
4	Panel frame	1	10318121203

5	Display panel	1	10318121204
6	Protector for temp sensor	1	10112121224
7	Clamp for temp sensor	1	10109121231
8	Horizontal louver , up	1	10318121205
9	Horizontal louver , down	1	10318121206
10	Louver motor	1	10316121202
11	Air out frame	1	10318121208
12	Left holder for evaporator	1	10318121210
13	Evaporator	1	10316121203
14	Bearing holder	1	10318121212
15	Cross flow fan, ass'y	1	10318121213
16	Left cover for chassis	1	10318121214
17	Chassis	1	10318121215
18	Installation plate	1	10318121216
19	Connecting pipe clamp	1	10318121217
20	Underlay for relay	1	10318121218
21	Right cover for chassis	1	10318121219
22	Protection box for relay	1	10318121220
23	Fan motor	1	10318121221
24	Motor cover	1	10318121222
25	Evaporator temp sensor	1	10109121242
26	Indoor temp sensor	1	10109121243
27	Drain hose	1	10318121223
28	Bush	2	10318121224
29	Louver	12	10318121225
30	Louver holder	2	10318121226
31	Connecting bar for louver	1	10318121227
32	E-part box cover	1	10318121228
33	Transformer	1	10109121204
34	E-parts box	1	10318121230
35	Main control board	1	10316121204
36	Display board , ass'y	1	10316121205
37	Display board enclosure	1	10318121233
38	Wire clamp for power cord	1	10318121234
39	Wire joint, 5p	1	10318121235
40	Wire clamp	1	10112121234
41	Holder, remote controller	1	10109121208

42	Remote controller	1	10109121207
43	Relay	1	10118121238
44	Switch board	1	10109121205
45	Connection pipe for drainage	1	11609121003
46	Sealing ring	1	31009321021
47	Copper nut, TLM-A01	1	10909121012
48	Copper nut, TLM-C03	1	10912121019

Exploded View Parts for Model GU-S18HR 220-240V~,50Hz : Outdoor Unit

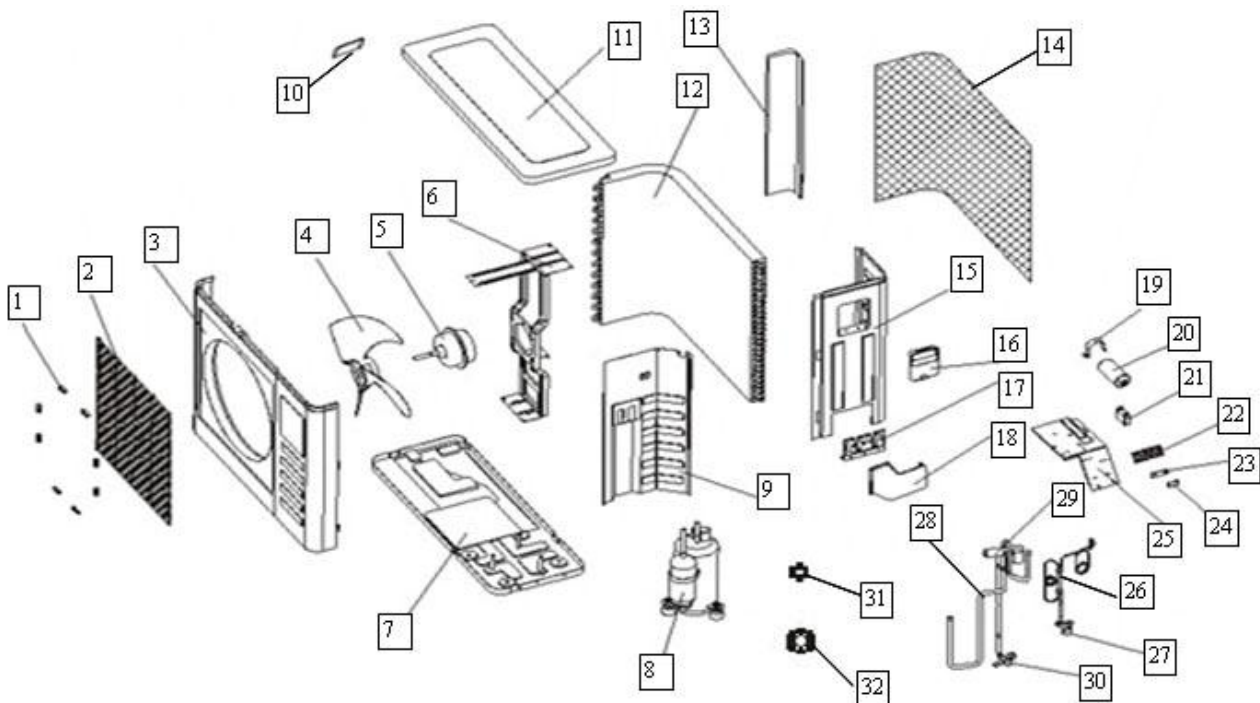

No.	Part Name	Quantity	Sale code
1	Clamp for front net	6	10112121801
2	Front net	1	10109121801
3	Front clapboard	1	13012111801
4	Propeller fan	1	10112121803
5	Fan motor	1	20412111801
6	Holder for fan motor	1	10312121002
7	Chassis	1	10116113806
8	Compressor	1	10116113807
9	Separating board	1	10116113813
10	Small Handle	1	10830121811
11	Cover	1	13012111805
12	Condenser	1	10116123801

13	Installation board , left	1	13012111803
14	Rear net	1	13012111806
15	Right clapboard	1	13012111808
16	Big handle	1	10112121808
17	Installation plate for valves	1	10118113805
18	Water collector	1	10118121832
19	Capacitor clamp	1	10118121823
20	Compressor capacitor	1	30324313020
21	Fan motor capacitor	1	10112121815
22	Wire joint	1	10109121823
23	Washer for wire joint	1	10112121817
24	Clamp for wiring	1	10718121809
25	Installation board for E-parts	1	15009111801
26	High Pressure Valve Ass'y	1	10116123802
27	Liquid pipe valve	1	10118121830
28	Low pressure Valve Ass'y	1	10116123803
29	4-way valve	1	10312121852
30	Low-pressure Valve	1	10312121858
31	Copper nut, TLM-A01	1	10909121012
32	Copper nut, TLM-B02	1	10912121019

Climatic Control Corporation. LLP
29-30 Margaret Street,
London W1R 6HH, UK
Tel./fax: +44 20 7016 9133